



US007126450B2

(12) **United States Patent**  
**Baarman et al.**

(10) **Patent No.:** **US 7,126,450 B2**

(45) **Date of Patent:** **Oct. 24, 2006**

(54) **INDUCTIVELY POWERED APPARATUS**

in-part of application No. 29/165,011, filed on Aug. 2, 2002, now Pat. No. Des. 478,834.

(75) Inventors: **David W. Baarman**, Fennville, MI (US); **Stephen J. McPhilliamy**, Chicago, IL (US); **Christopher Houghton**, Chicago, IL (US)

(60) Provisional application No. 60/140,159, filed on Jun. 21, 1999, provisional application No. 60/140,090, filed on Jun. 21, 1999.

(73) Assignee: **Access Business Group International LLC**, Ada, MI (US)

(51) **Int. Cl.**  
**H01F 5/00** (2006.01)

(\*) Notice: Subject to any disclaimer, the term of this patent is extended or adjusted under 35 U.S.C. 154(b) by 235 days.

(52) **U.S. Cl.** ..... **336/121; 315/276**

(58) **Field of Classification Search** ..... **315/274, 315/275, 276, 277, 278, 281, 282; 336/121, 336/122, 123, 124, 125, 126**

See application file for complete search history.

(21) Appl. No.: **10/357,932**

(56) **References Cited**

(22) Filed: **Feb. 4, 2003**

**U.S. PATENT DOCUMENTS**

(65) **Prior Publication Data**

US 2003/0214255 A1 Nov. 20, 2003

**Related U.S. Application Data**

(63) Continuation-in-part of application No. 10/133,860, filed on Apr. 26, 2002, now Pat. No. 6,731,071, and a continuation-in-part of application No. 10/246,155, filed on Sep. 18, 2002, now Pat. No. 6,825,620, and a continuation-in-part of application No. 09/592,194, filed on Jun. 12, 2000, now Pat. No. 6,436,299, and a continuation-in-part of application No. 10/175,095, filed on Jun. 12, 2000, now Pat. No. 6,436,299, which is a continuation-in-part of application No. 09/592,194, filed on Jun. 12, 2000, now Pat. No. 6,436,299, application No. 10/357,932, which is a continuation-in-part of application No. 29/165,043, filed on Aug. 2, 2002, now Pat. No. Des. 476,095, and a continuation-in-part of application No. 29/165,008, filed on Aug. 2, 2002, now Pat. No. Des. 479,356, and a continuation-in-part of application No. 29/165,012, filed on Aug. 2, 2002, now Pat. No. Des. 476,094, and a continuation-in-part of application No. 29/165,005, filed on Aug. 2, 2002, now Pat. No. Des. 479,892, and a continuation-in-part of application No. 29/165,009, filed on Aug. 2, 2002, now Pat. No. Des. 475,471, and a continuation-

602,966 A	4/1898	Wallach
843,534 A	2/1907	Hewitt
1,137,333 A	4/1915	Klorer
1,604,870 A	10/1926	Asman
1,803,571 A	5/1931	Ulman
1,852,740 A	4/1932	Doane
2,199,107 A	4/1940	Kibbe
2,265,475 A	12/1941	Fodor
2,353,063 A	7/1944	Otis
2,686,866 A	8/1954	Williams
2,726,116 A	12/1955	Barber
2,731,547 A	1/1956	Callard
3,047,765 A	7/1962	Vichill
3,292,579 A	12/1966	Buchanan
3,550,682 A	12/1970	Fowler
3,551,091 A	12/1970	Veloz
3,628,086 A	12/1971	Nuckolls
3,641,336 A	2/1972	Boin
3,743,989 A	7/1973	Nicolas et al.
3,746,906 A	7/1973	Cardwell, Jr.
3,867,661 A	2/1975	Waltz et al.
3,885,185 A	5/1975	Tilley
3,885,211 A	5/1975	Gutai
3,923,663 A	12/1975	Reid
3,938,018 A	2/1976	Dahl
4,005,330 A	1/1977	Glascoek, Jr. et al.
4,010,400 A	3/1977	Hollister
4,017,764 A	4/1977	Anderson
4,038,625 A	7/1977	Tompkins et al.

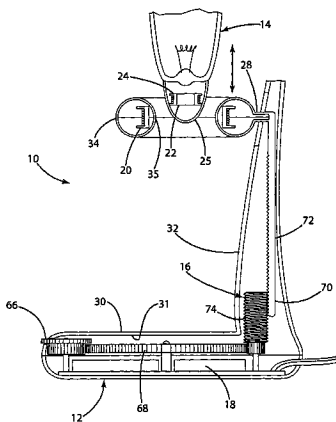

4,093,893 A	6/1978	Anderson	5,747,894 A	5/1998	Hirai et al.
4,101,777 A	7/1978	Reid	5,771,438 A	6/1998	Palermo et al.
4,117,378 A	9/1978	Glascocock, Jr.	5,814,900 A	9/1998	Esser et al.
4,160,193 A *	7/1979	Richmond ..... 315/281	5,831,348 A	11/1998	Nishizawa
4,282,563 A	8/1981	Ohta et al.	5,831,516 A	11/1998	Jennings
4,300,073 A	11/1981	Skwirut et al.	5,834,905 A	11/1998	Godyak et al.
4,389,595 A	6/1983	Kamei et al.	5,905,343 A	5/1999	McCamant
4,414,489 A	11/1983	Young	5,923,544 A	7/1999	Urano
4,431,948 A *	2/1984	Elder et al. .... 315/276	5,928,505 A	7/1999	Inakagata et al.
4,584,707 A	4/1986	Goldberg et al.	5,929,598 A	7/1999	Nakama et al.
4,615,799 A	10/1986	Mortensen	5,949,155 A	9/1999	Tamura et al.
4,637,434 A	1/1987	Moen	5,951,155 A	9/1999	Lanser
4,675,573 A	6/1987	Miram et al.	5,952,814 A	9/1999	VanLergerghe
4,675,638 A	6/1987	Szabo	5,980,056 A	11/1999	West
4,747,158 A	5/1988	Goldberg et al.	5,990,611 A	11/1999	Lee
4,752,401 A	6/1988	Bodenstein	6,005,304 A	12/1999	Seelig
4,754,180 A *	6/1988	Kiedrowski ..... 310/90.5	6,020,682 A	2/2000	Holzer
4,762,613 A	8/1988	Snowball	6,027,225 A	2/2000	Martin et al.
4,772,991 A	9/1988	Wood	6,028,413 A	2/2000	Brockmann
4,800,328 A	1/1989	Bolger et al.	6,075,433 A	6/2000	Ono et al.
4,812,702 A	3/1989	Anderson	6,118,249 A	9/2000	Brockmann et al.
4,816,977 A	3/1989	Sorensen	6,160,371 A	12/2000	Tachikawa
4,818,855 A	4/1989	Mongeon et al.	6,161,032 A	12/2000	Acker
4,838,797 A	6/1989	Dodier	6,166,494 A	12/2000	Green
4,854,214 A	8/1989	Lowe	6,188,179 B1	2/2001	Boys et al.
4,857,204 A	8/1989	Joklik	6,194,828 B1	2/2001	Kohne et al.
4,894,591 A	1/1990	Witting	6,218,785 B1	4/2001	Incerti
4,954,756 A	9/1990	Wood et al.	6,241,359 B1	6/2001	Lin
4,958,266 A	9/1990	Sorensen et al.	6,252,380 B1	6/2001	Koenck
4,968,437 A	11/1990	Noll et al.	6,263,247 B1	7/2001	Mueller et al.
4,971,687 A	11/1990	Anderson	6,275,143 B1	8/2001	Stobbe
4,972,120 A	11/1990	Witting	6,280,066 B1	8/2001	Dolan
4,977,354 A	12/1990	Bergervoet et al.	6,291,936 B1	9/2001	MacLennan et al.
5,030,889 A	7/1991	El-Hamamsy et al.	6,301,128 B1	10/2001	Jang et al.
5,039,903 A	8/1991	Farrall	6,307,316 B1	10/2001	Holzer
5,041,763 A	8/1991	Sullivan et al.	6,322,226 B1	11/2001	Dickson
5,054,112 A	10/1991	Ike	6,326,739 B1	12/2001	MacLennan et al.
5,070,293 A	12/1991	Ishii et al.	6,339,296 B1	1/2002	Goral
5,101,332 A	3/1992	Hsia	6,345,203 B1	2/2002	Mueller et al.
5,122,729 A	6/1992	Itoga et al.	6,436,299 B1	8/2002	Baarman et al.
5,141,325 A	8/1992	Huang	6,459,882 B1	10/2002	Palermo et al.
5,146,140 A	9/1992	Piejak et al.	6,462,432 B1	10/2002	Seelig et al.
5,158,361 A	10/1992	Huang	6,597,076 B1	7/2003	Scheible et al.
5,184,891 A	2/1993	Shpigel	6,794,831 B1 *	9/2004	Leeb et al. .... 315/307
5,216,402 A	6/1993	Carosa	2003/0006880 A1	1/2003	Zimmer
5,229,652 A	7/1993	Hough	2003/0222769 A1	12/2003	Mau
5,264,997 A	11/1993	Hutchisson et al.			
5,267,997 A	12/1993	Farin et al.			
5,280,416 A	1/1994	Hartley et al.			
5,289,085 A	2/1994	Godyak et al.	AT	370929	5/1983
5,300,860 A	4/1994	Godyak et al.	AU	A-61741/86	2/1988
5,301,096 A	4/1994	Klontz et al.	DE	2029468	12/1971
5,311,028 A	5/1994	Glavish	DE	4100272	7/1991
5,339,233 A	8/1994	Yang	DE	9012505	8/1991
5,341,280 A	8/1994	Divan et al.	DE	4238388	5/1994
5,416,388 A	5/1995	Shackle	DE	4421253	3/1995
5,422,519 A	6/1995	Russell	DE	4412957	10/1995
5,450,305 A	9/1995	Boys et al.	DE	19540854	5/1997
5,455,466 A	10/1995	Parks et al.	EP	0825577	2/1998
5,455,467 A	10/1995	Young et al.	GB	1349788	4/1974
5,465,025 A	11/1995	Hendrickson	GB	2388715 A	11/2003
5,506,560 A	4/1996	Takeuchi et al.	GB	2388716 A	11/2003
5,536,979 A	7/1996	McEachern et al.	JP	8-31585	6/1996
5,550,452 A	8/1996	Shirai et al.	WO	WO 97/17761	5/1997
5,553,312 A	9/1996	Gatthey et al.	WO	WO 97/26704	7/1997
5,594,304 A	1/1997	Graber	WO	WO 97/26705	7/1997
5,600,225 A	2/1997	Goto	WO	WO 00/22892	4/2000
5,611,918 A	3/1997	Markham	WO	WO 00/32298	6/2000
5,619,182 A	4/1997	Robb	WO	WO 00/54387	9/2000
5,653,531 A	8/1997	Yang	WO	WO 01/26427	4/2001
5,675,677 A	10/1997	Davenport et al.	WO	WO 01/26431	4/2001
5,680,028 A	10/1997	McEachern	WO	WO 01/80396 A1	10/2001
5,716,126 A	2/1998	Meyer	WO	WO 03/096361	11/2003

FOREIGN PATENT DOCUMENTS

WO WO 03/105311 12/2003

OTHER PUBLICATIONS

Gulko, Michael, et al, Inductor-Controlled Current-Sourcing Resonant Inverter and its Application as a High Pressure Discharge Lamp Driver, IEEE, pp. 434-440, May 1994.

"A Contactless Electrical Energy Transmission System for Portable-Telephone Battery Chargers", IEEE Transactions on Industrial Electronics, vol. 50, No. 3, Jun. 2003.

"Best of Show", Fortune, Feb. 17, 2003.

"Splashpower", www.splashpower.com, Feb. 11, 2003.

"Mobilewise", www.mobilewise.com, Feb. 11, 2003.

\* cited by examiner

*Primary Examiner*—David Vu

(74) *Attorney, Agent, or Firm*—Warner, Norcross & Judd

(57)

**ABSTRACT**

An inductive power supply system for providing power to one or more inductively powered devices. The system

includes a mechanism for varying the physical distance or the respective orientation between the primary coil and secondary coil to control the amount of power supplied to the inductively powered device. In another aspect, the present invention is directed to an inductive power supply system having a primary coil and a receptacle disposed within the magnetic field generated by the primary coil. One or more inductively powered devices are placed randomly within the receptacle to receive power inductively from the primary coil. The power supply circuit includes circuitry for adjusting the power supplied to the primary coil to optimize operation based on the position and cumulative characteristics of the inductively powered device(s) disposed within the receptacle.

**16 Claims, 27 Drawing Sheets**

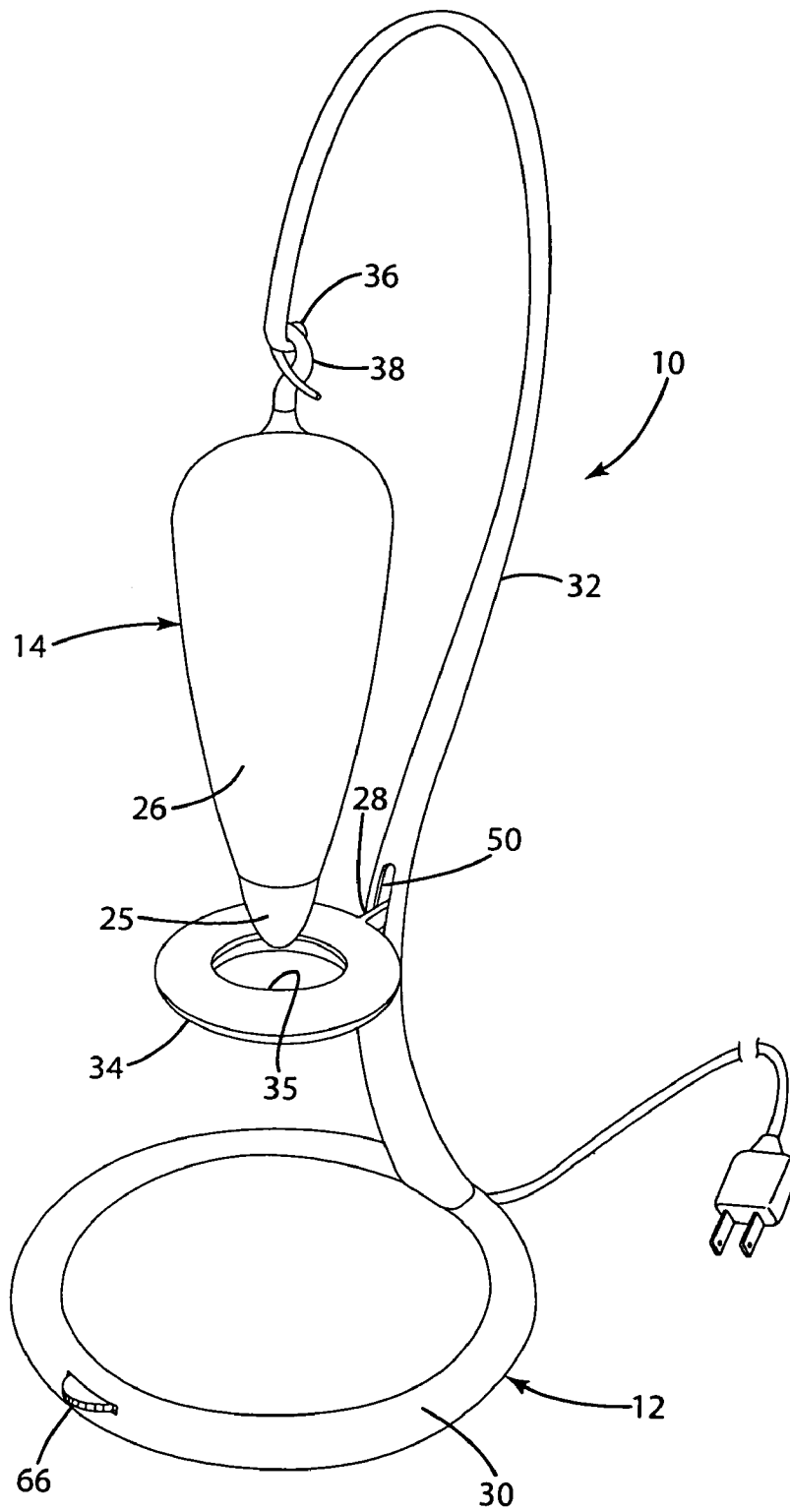

Fig. 1

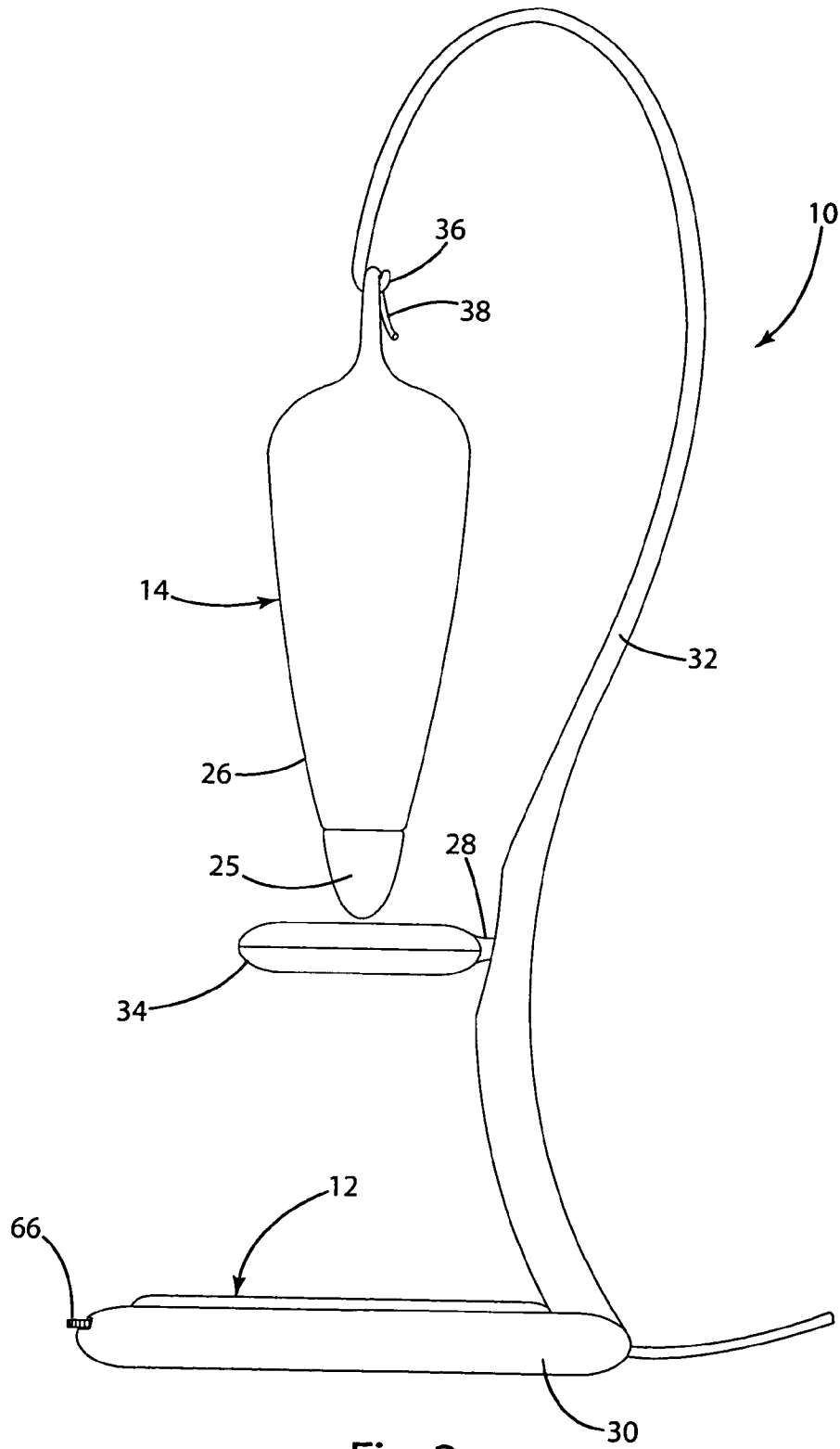

Fig. 2

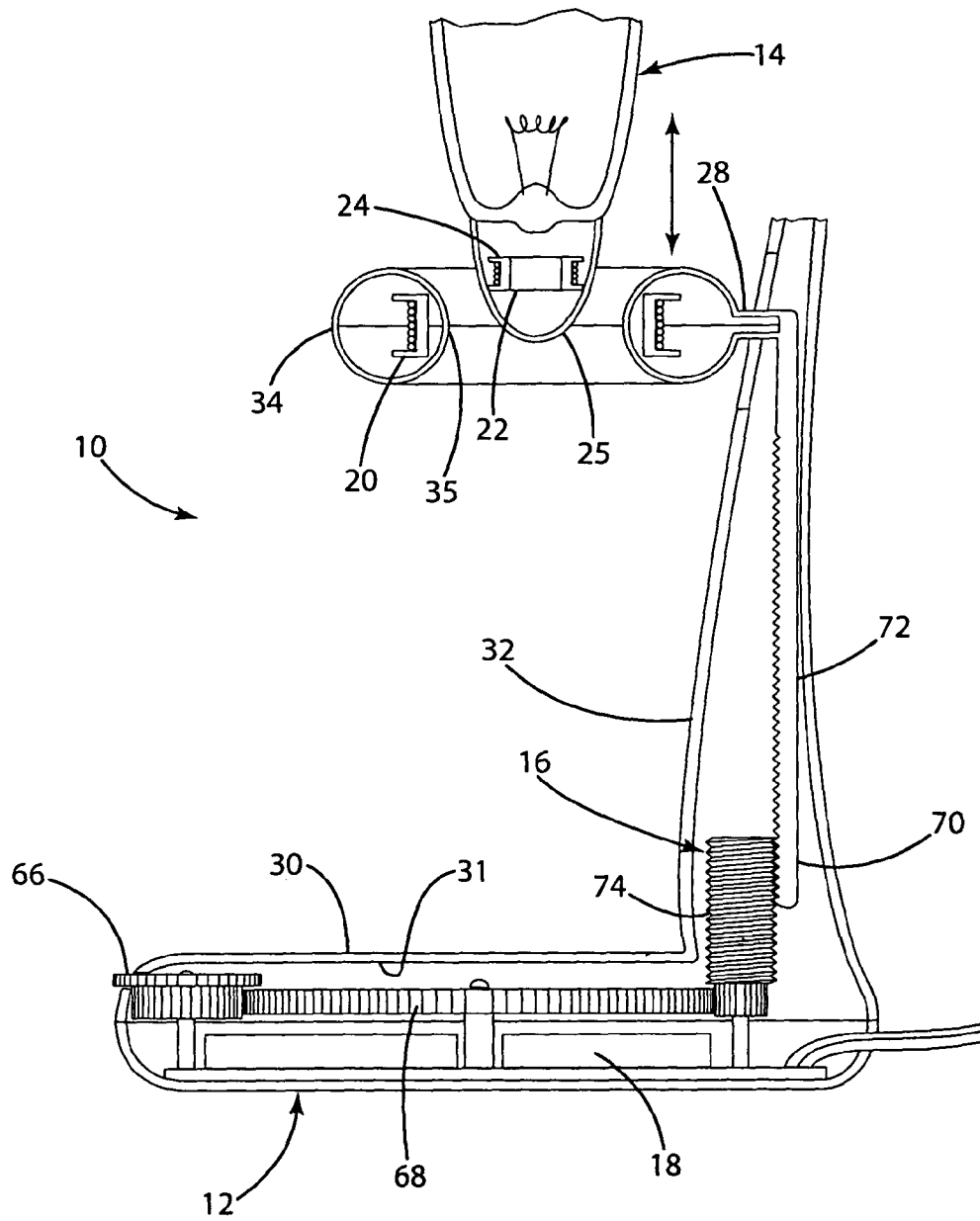

Fig. 3

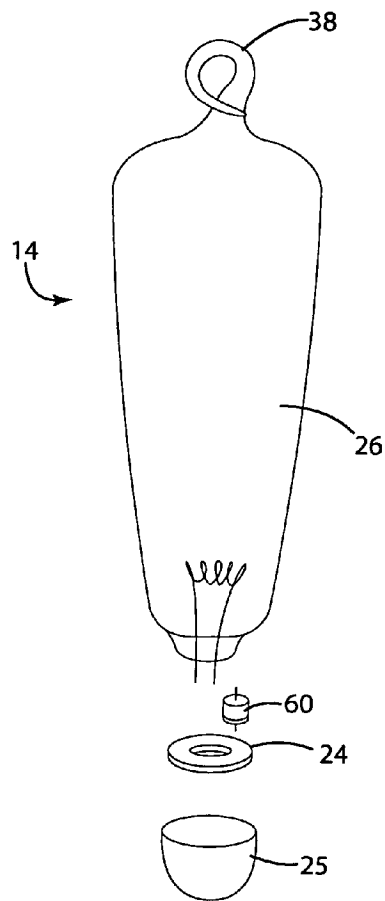

Fig. 4

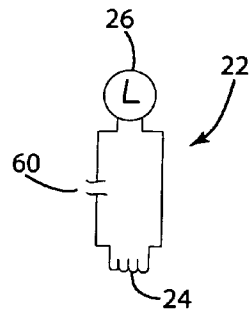

Fig. 5

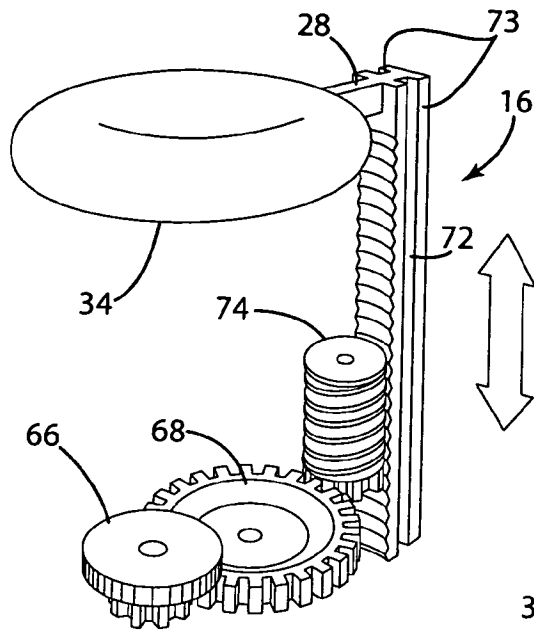

Fig. 6

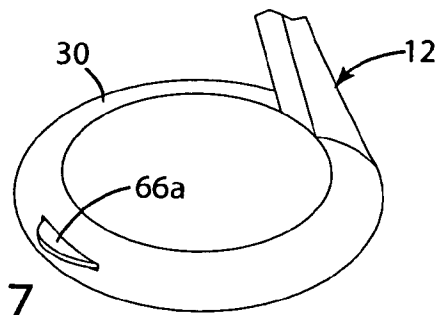

Fig. 7

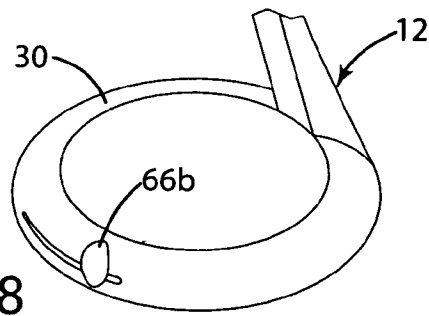

Fig. 8

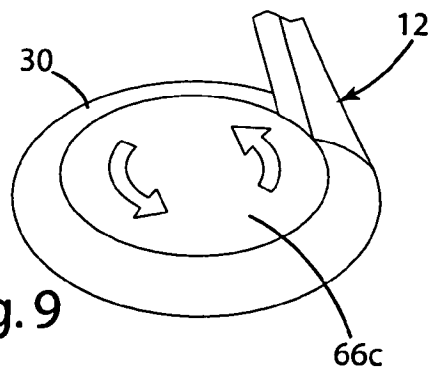

Fig. 9

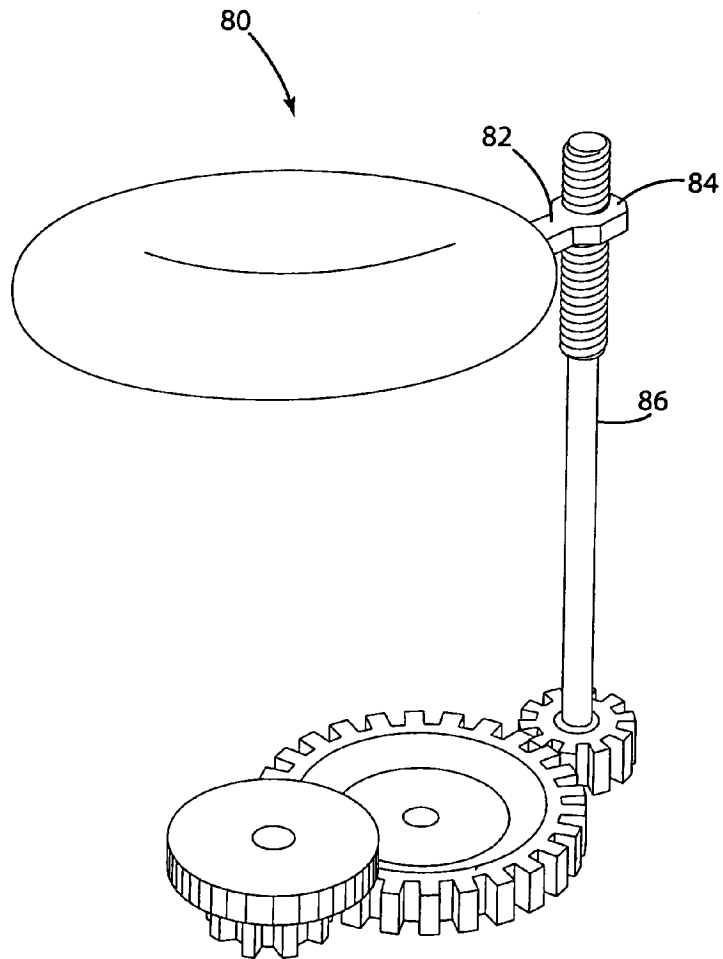

Fig. 10

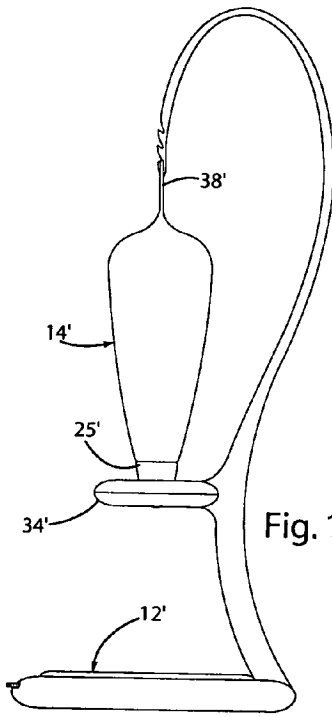

Fig. 11a

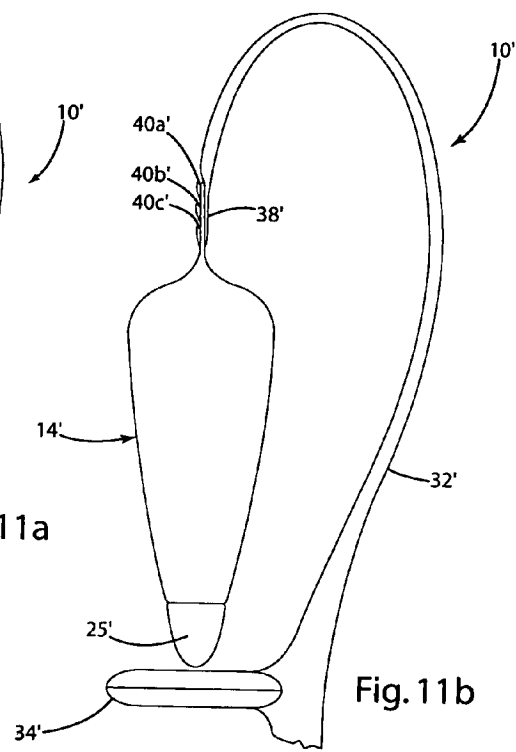

Fig. 11b

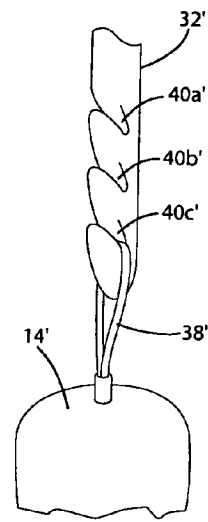
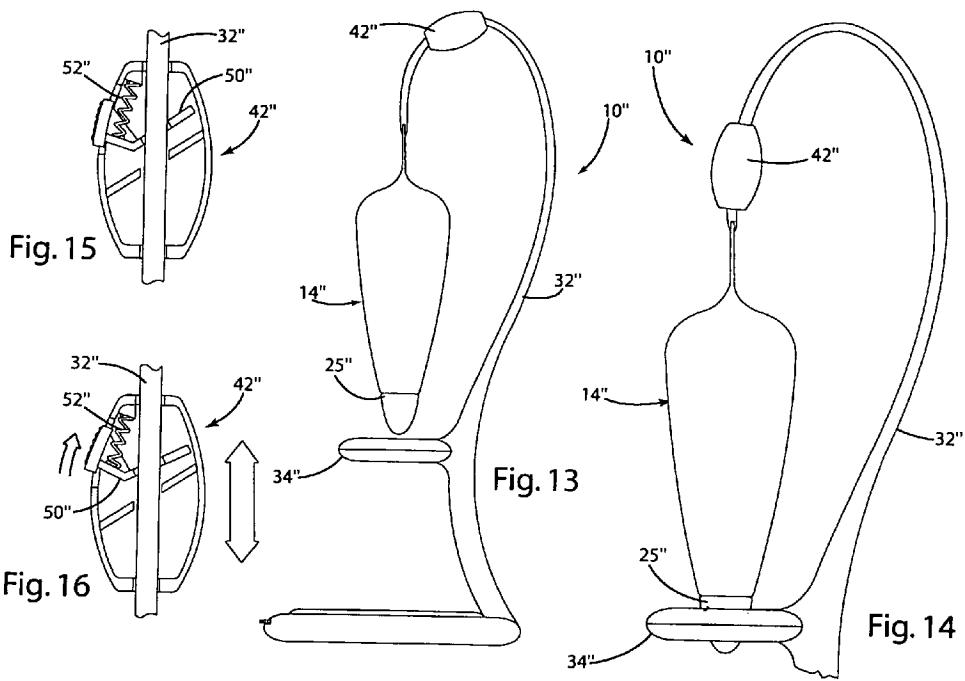

Fig. 12



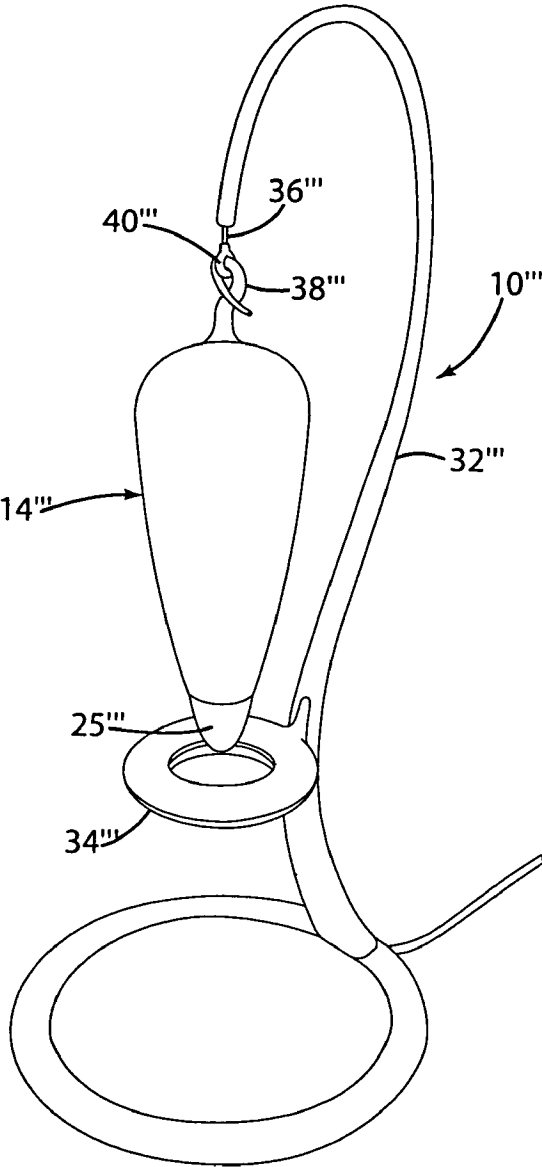

Fig. 17

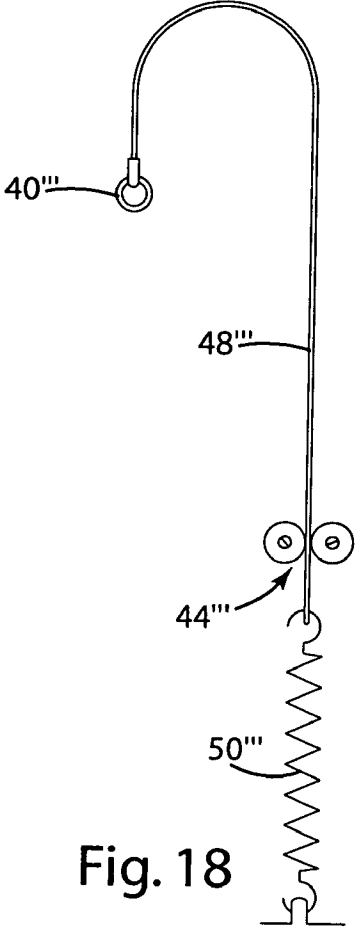

Fig. 18

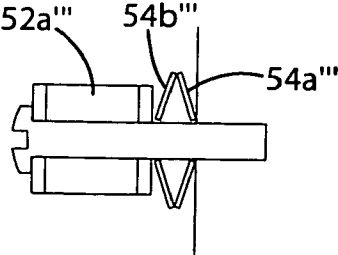

Fig. 19

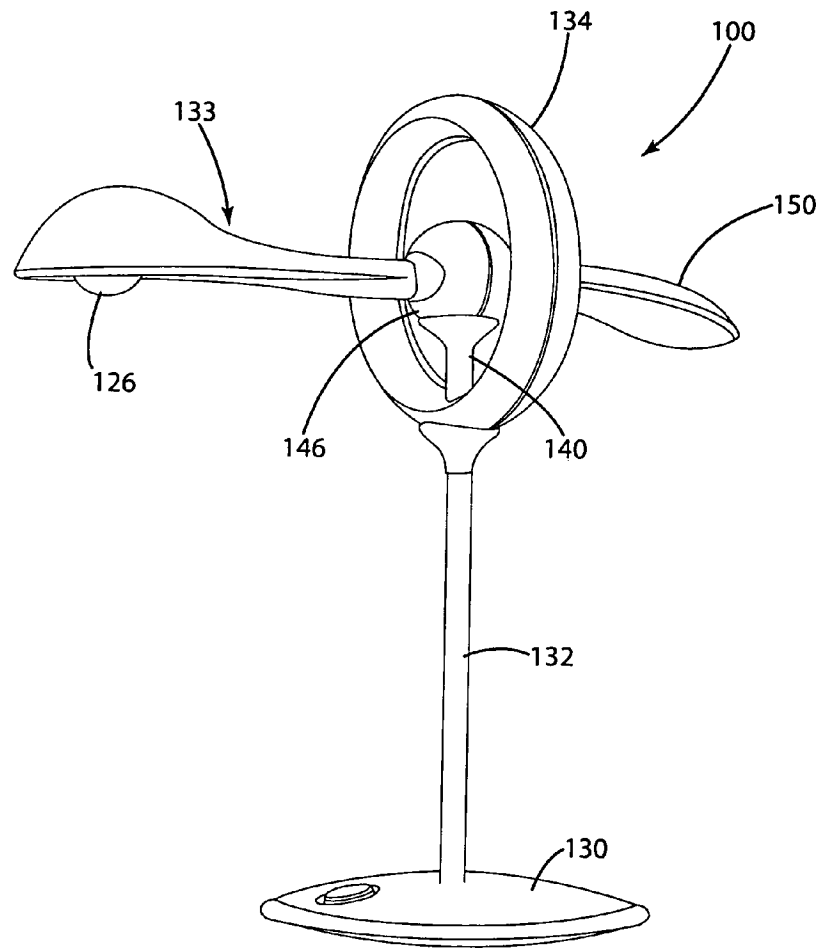

Fig. 20

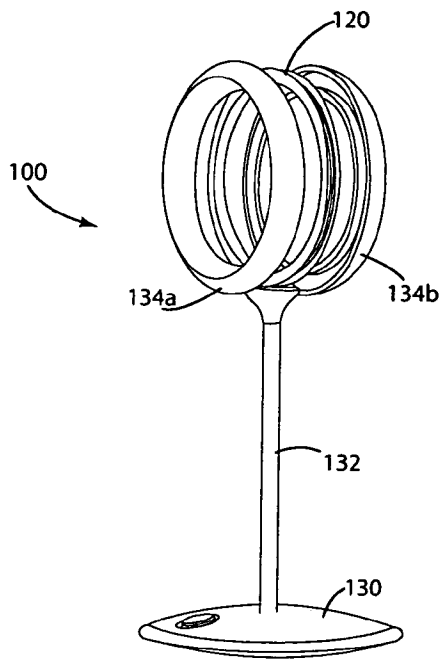

Fig. 22

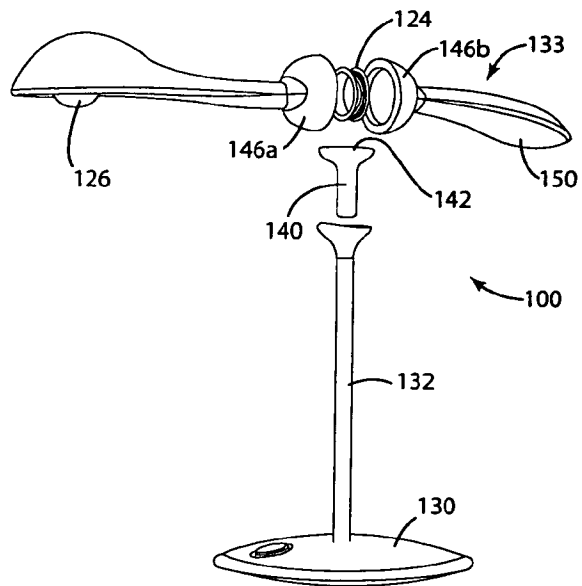

Fig. 21

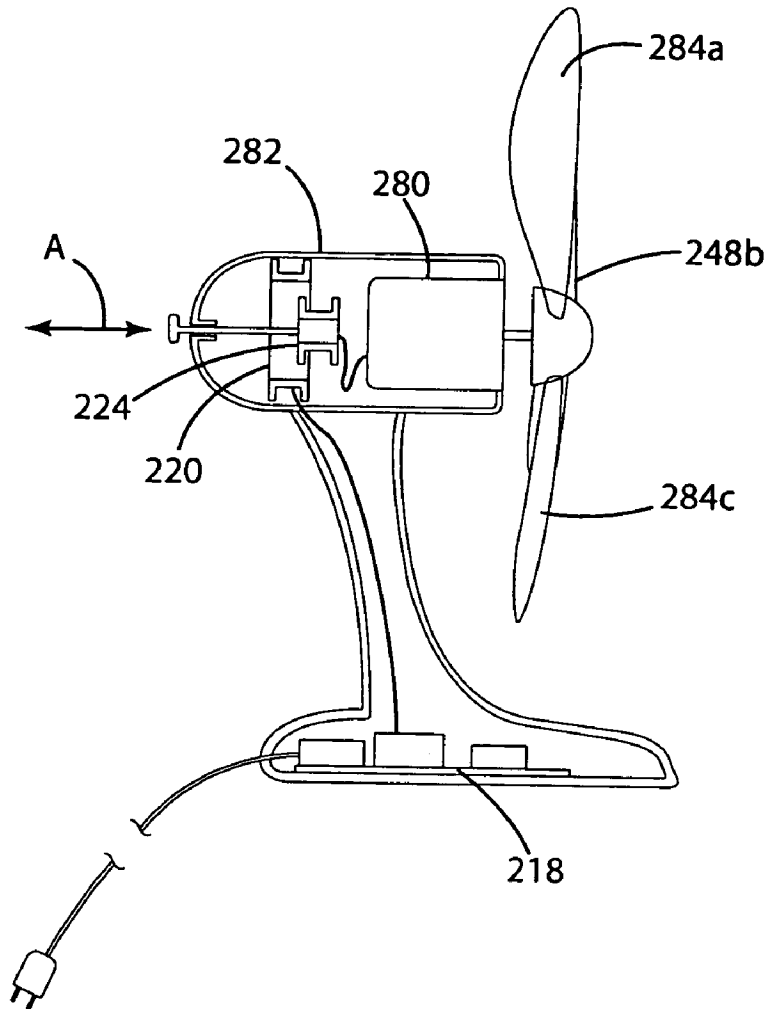

Fig. 23

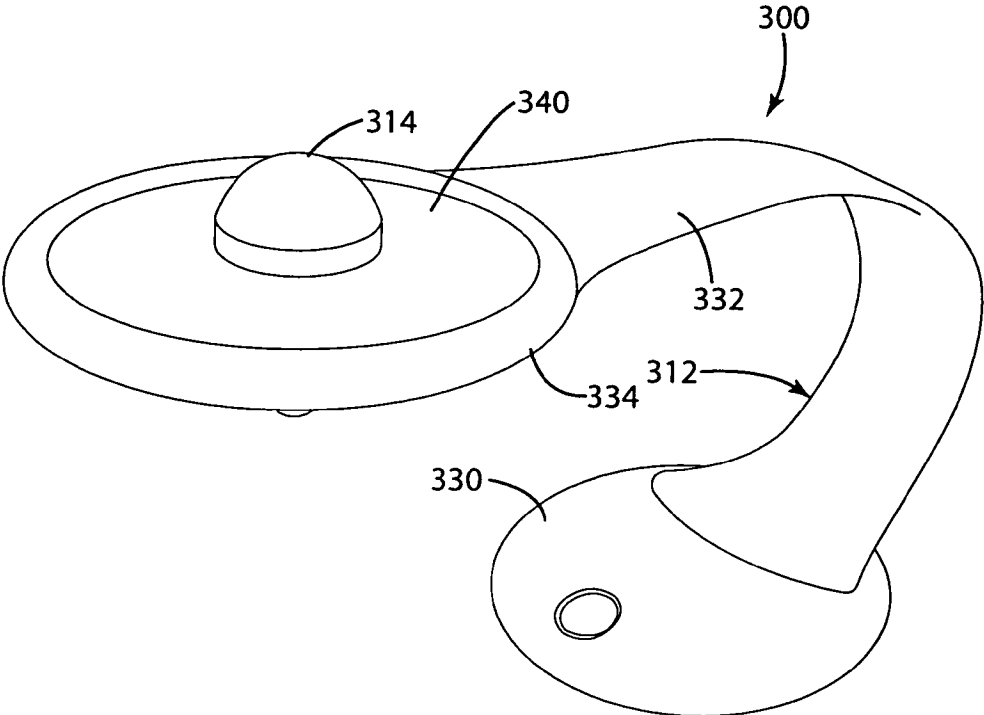

Fig. 24

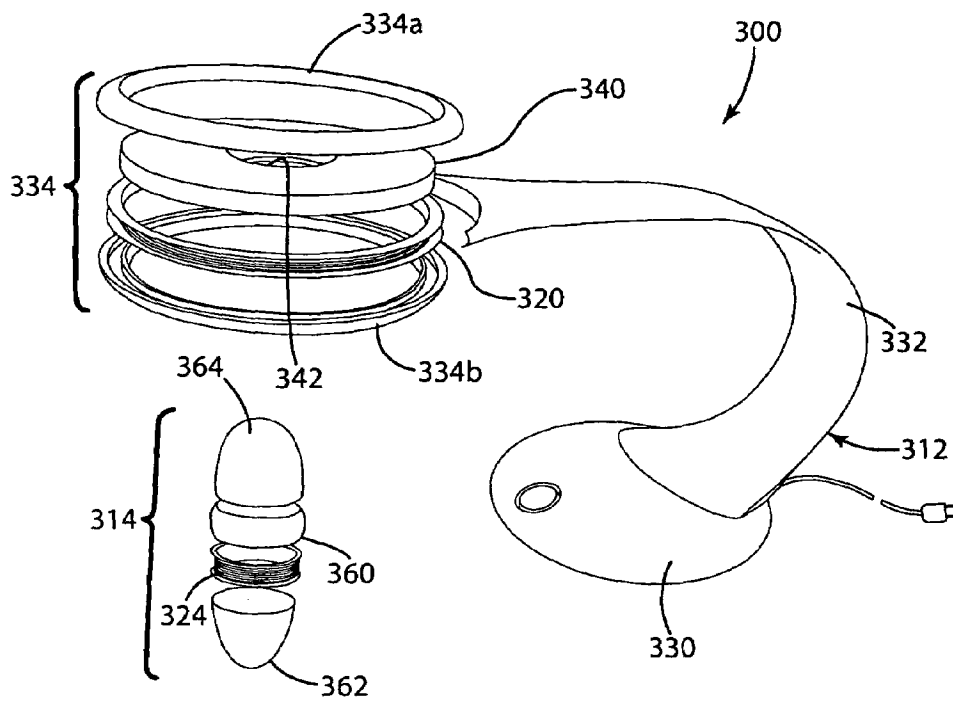

Fig. 25

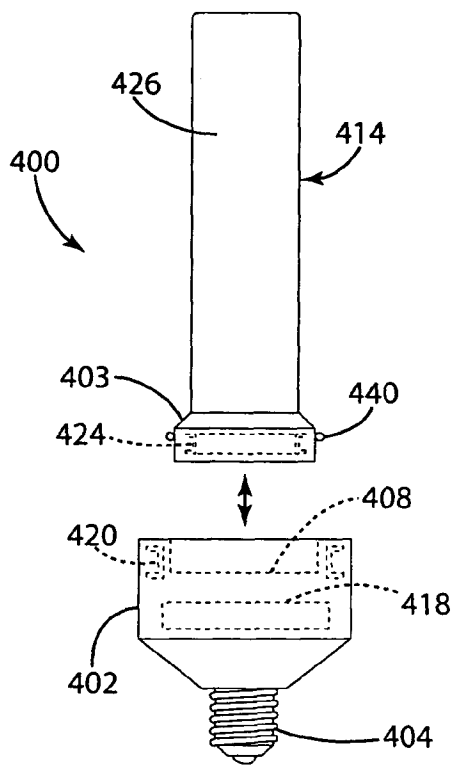

Fig. 26

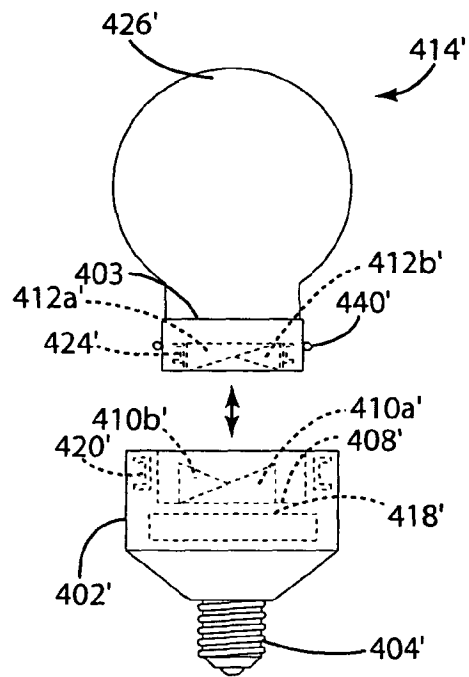

Fig. 27

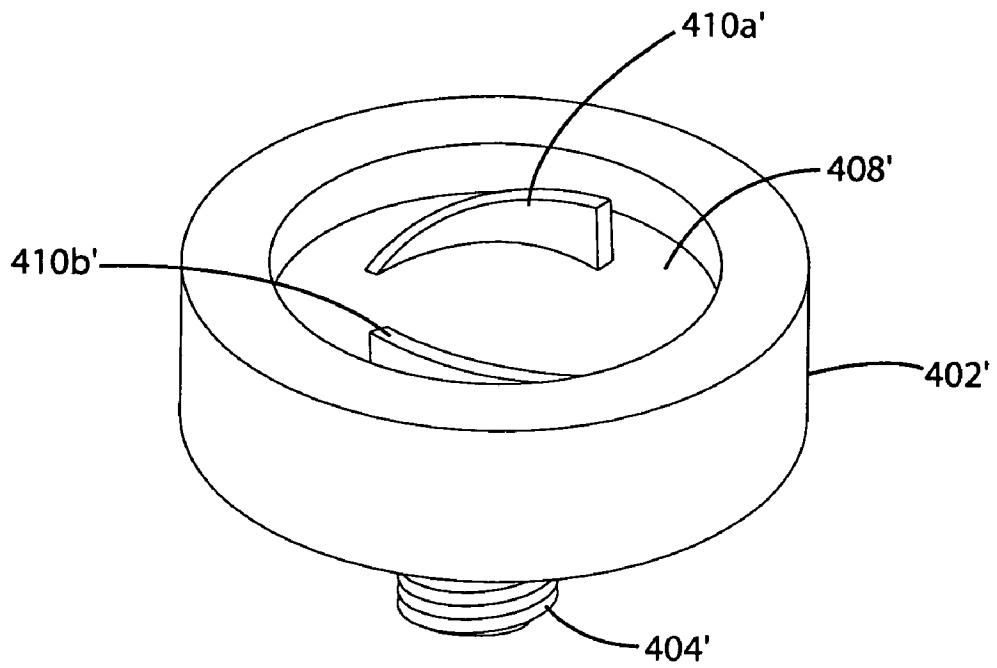

Fig. 28

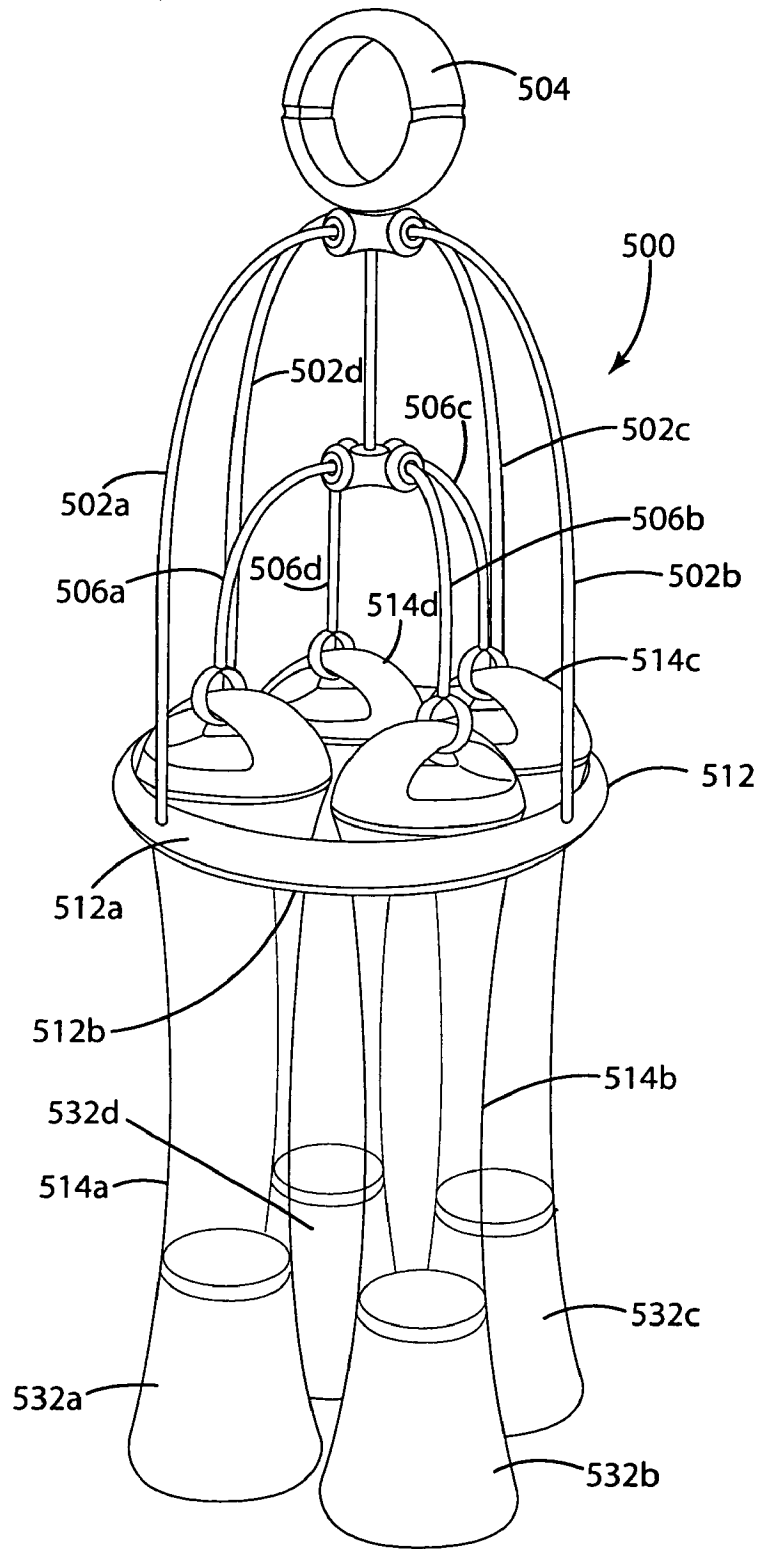

Fig. 29

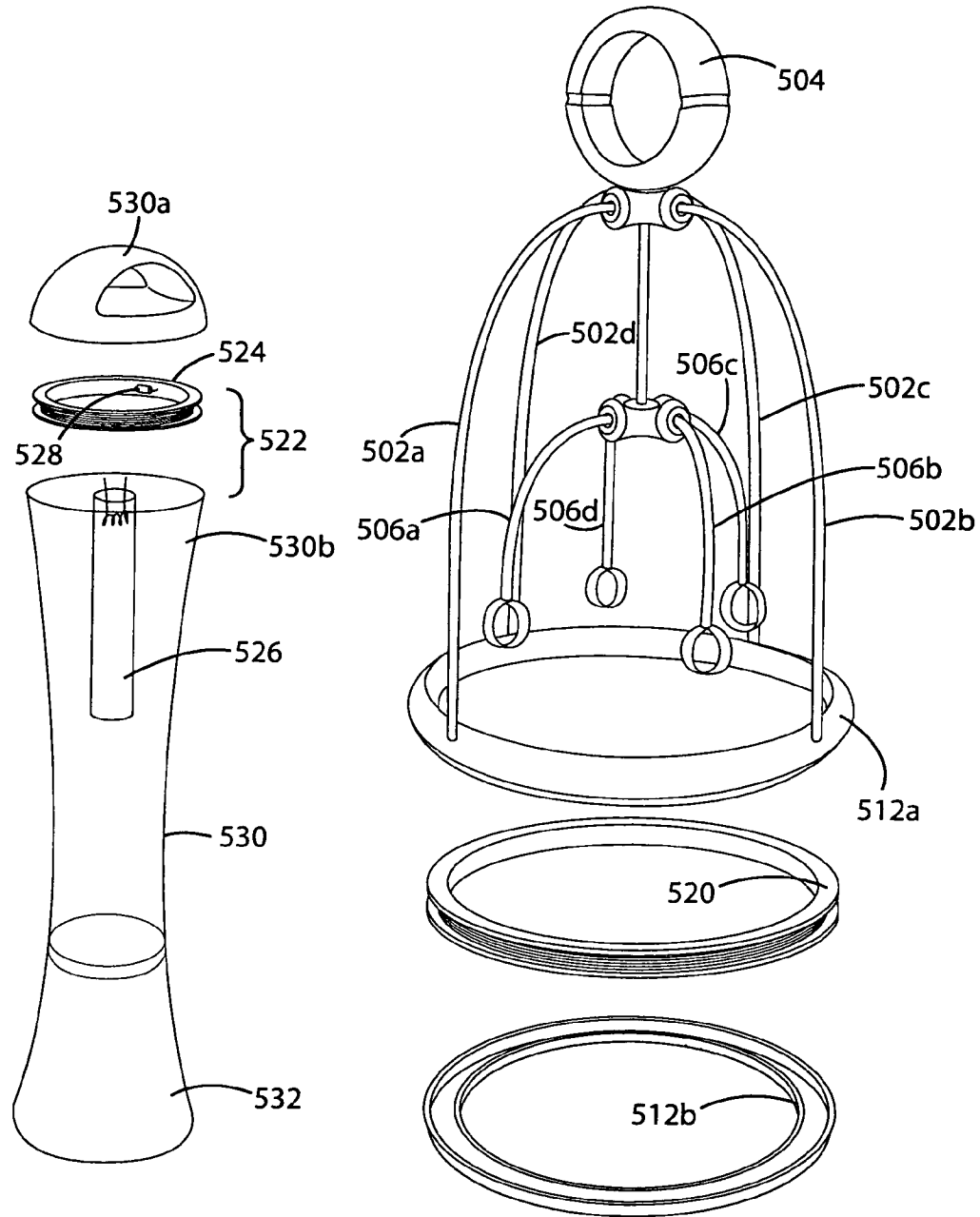

Fig. 31

Fig. 30

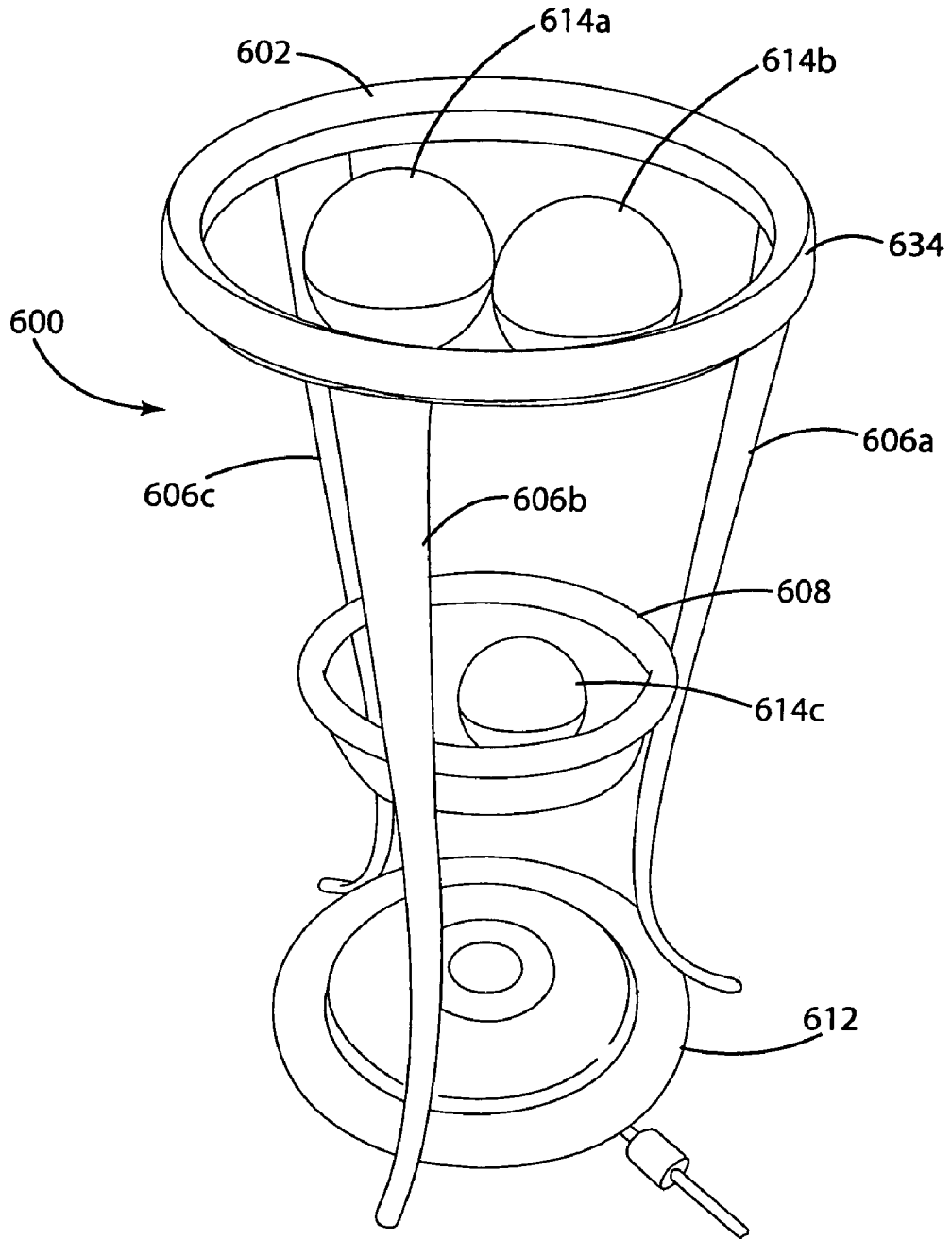

Fig. 32

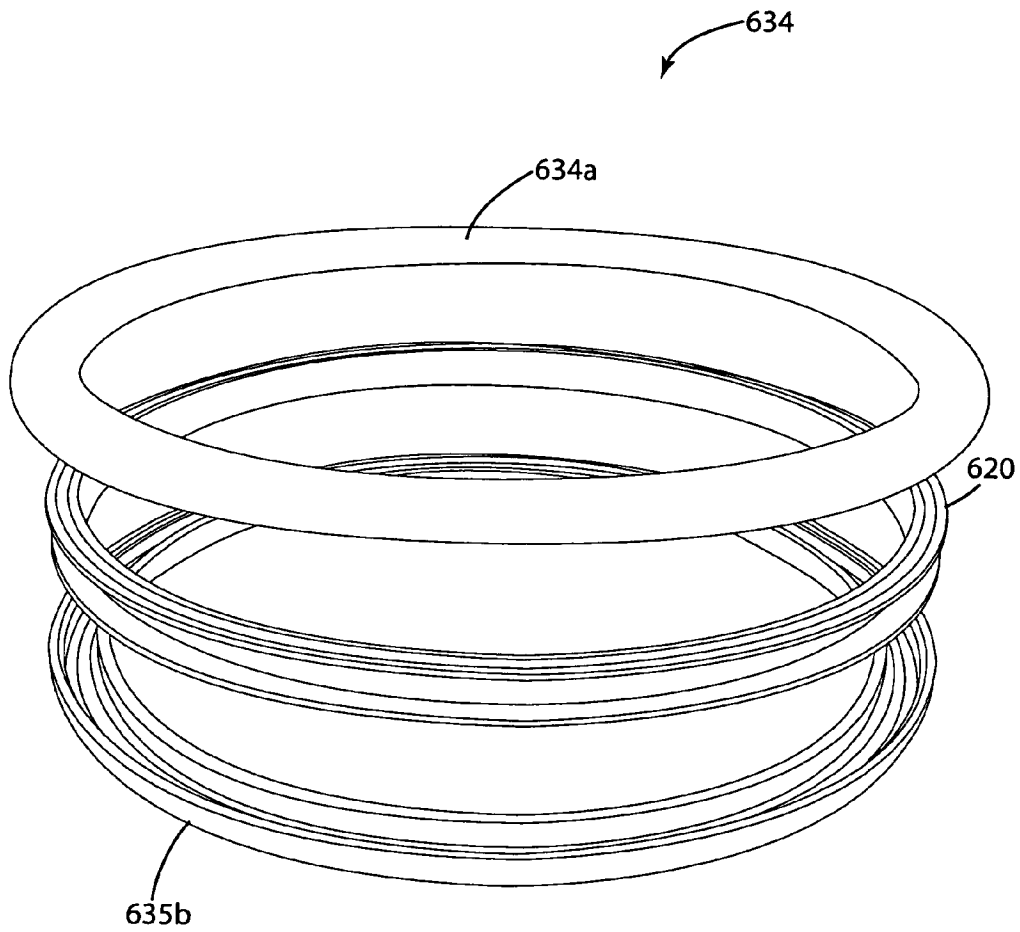

Fig. 33

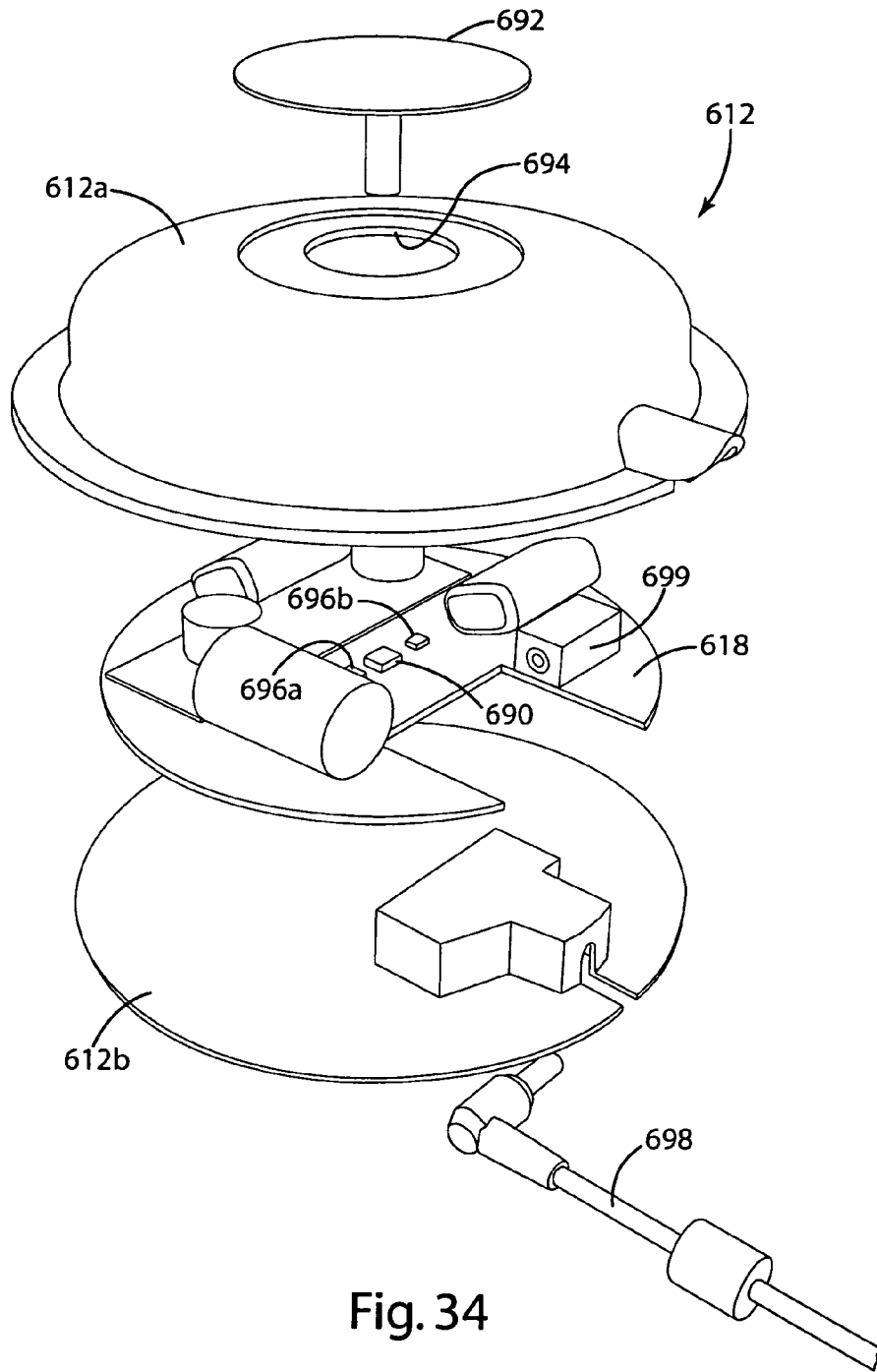

Fig. 34

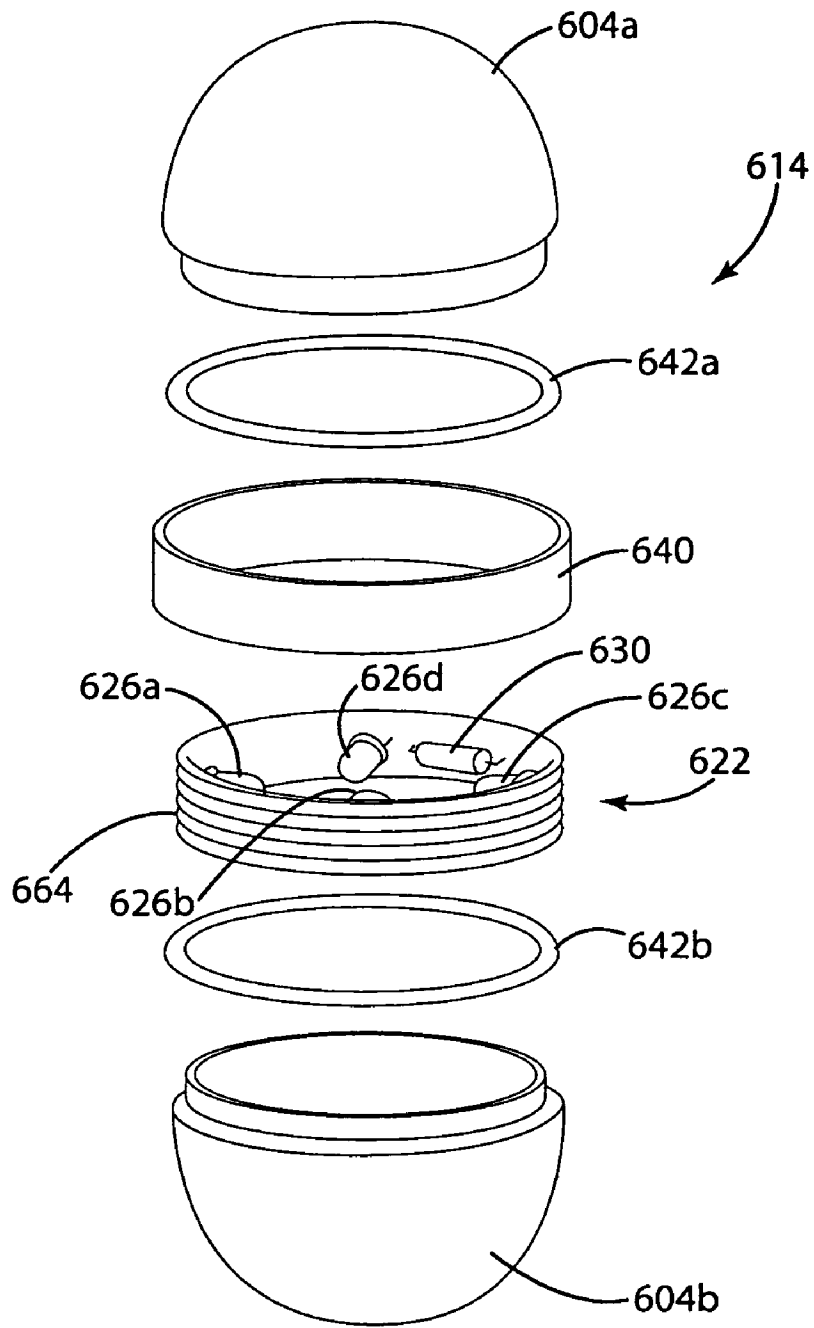

Fig. 35

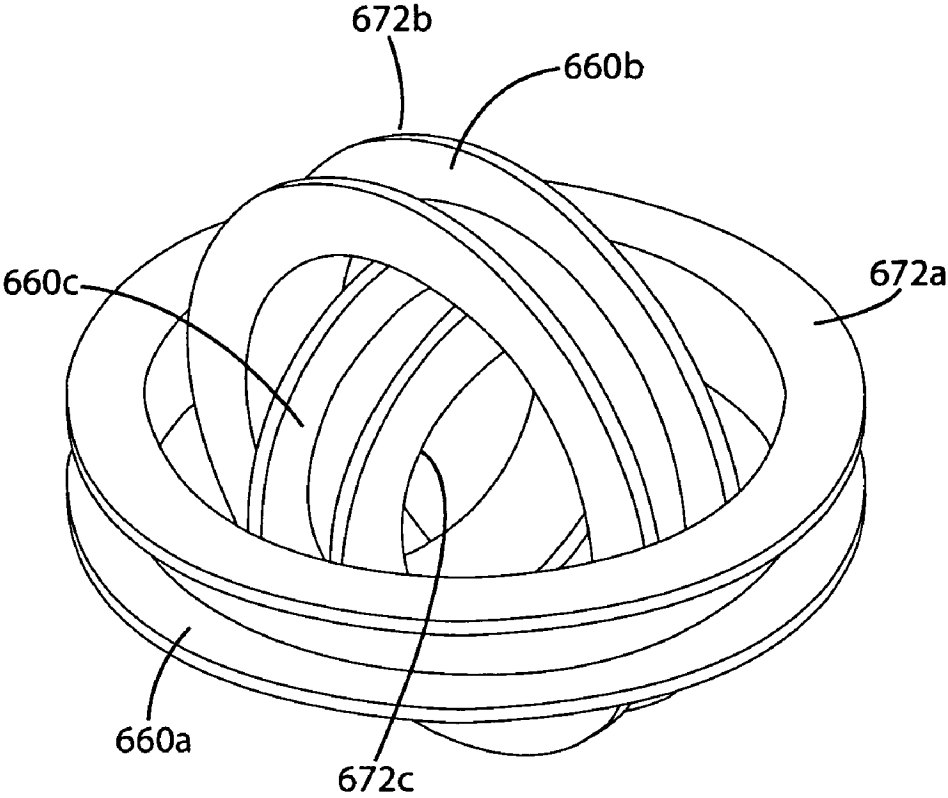

Fig. 36

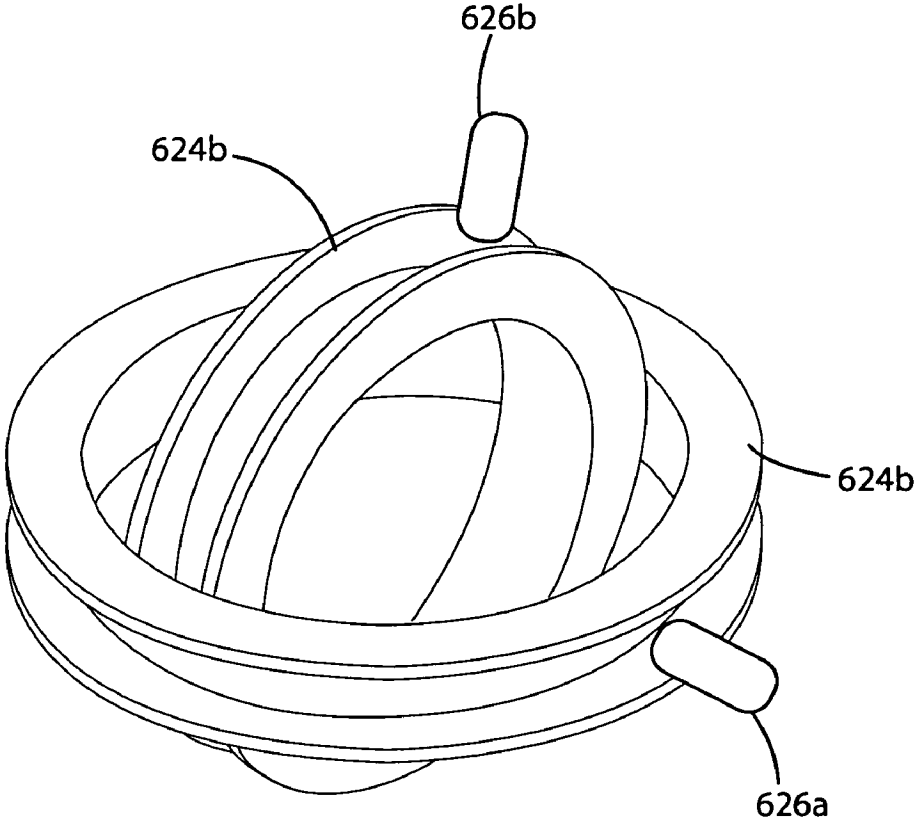

Fig. 37

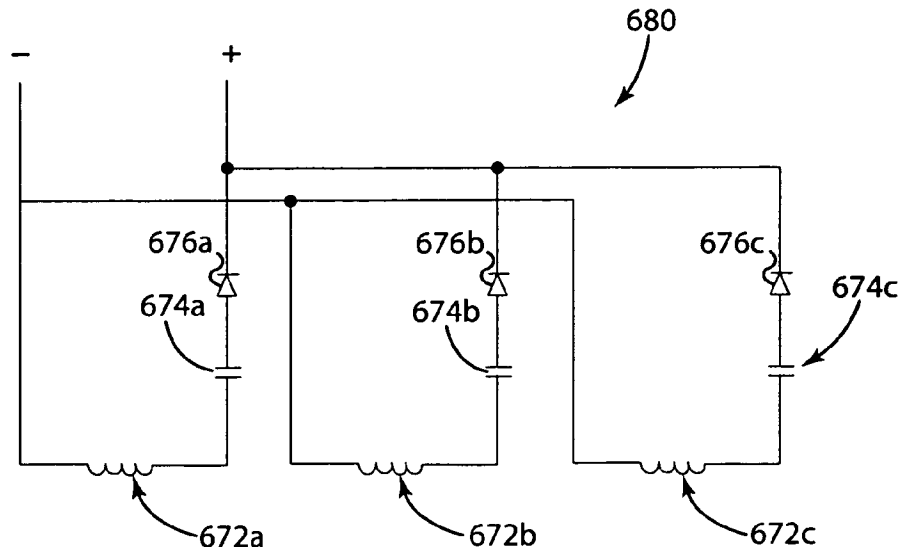

Fig. 38a

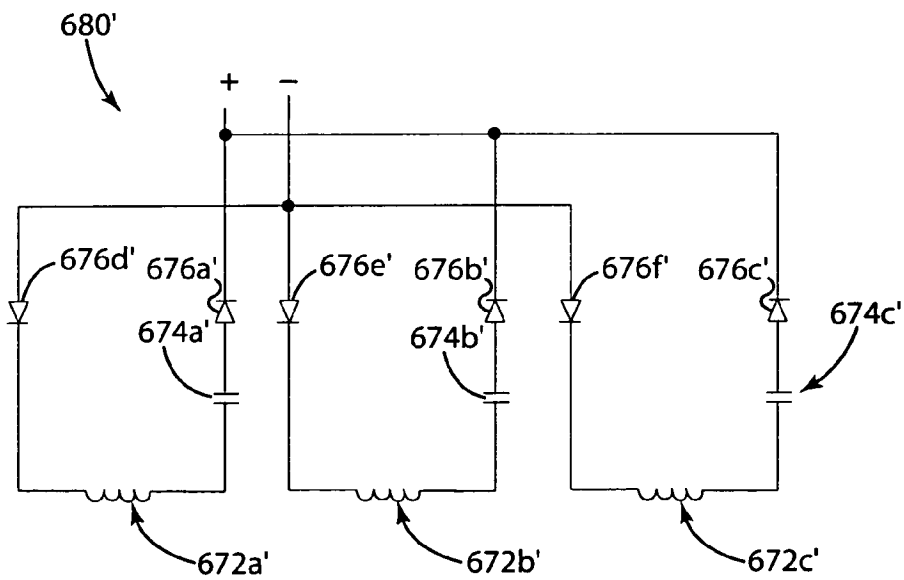

Fig. 38b

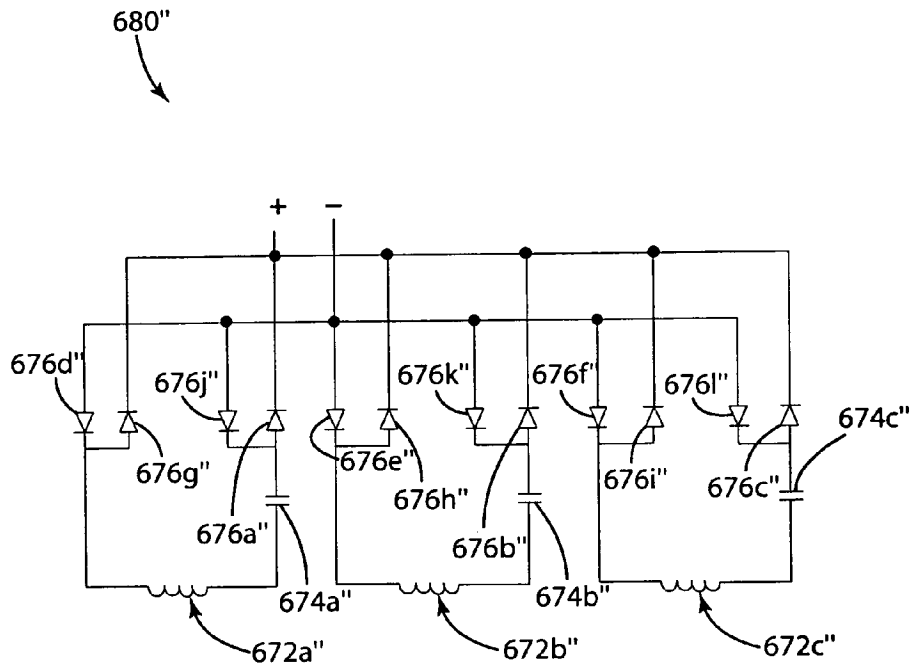
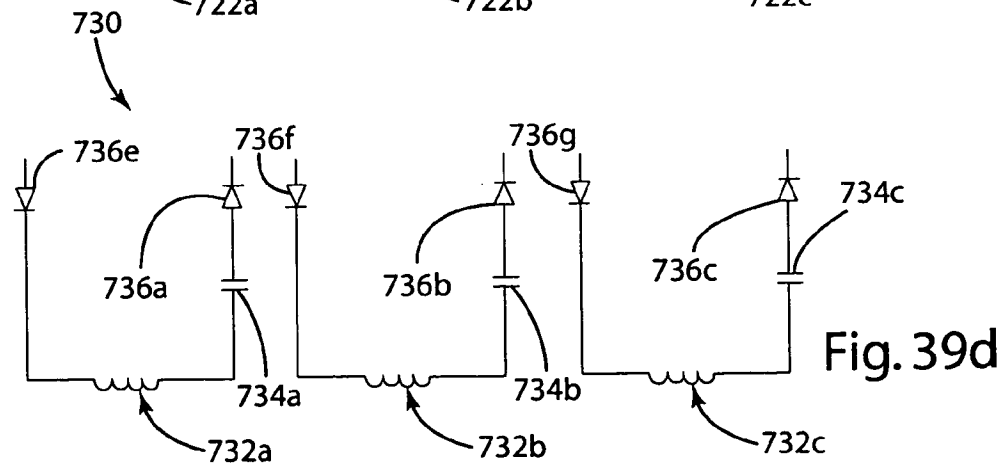
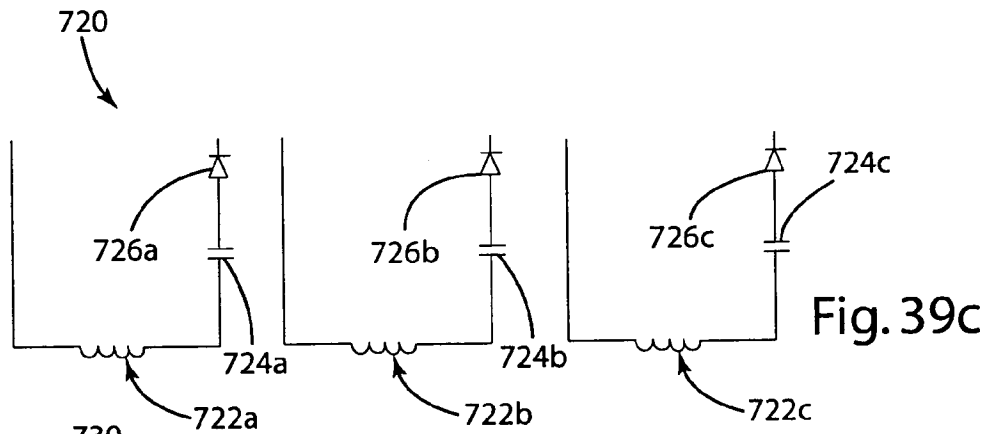
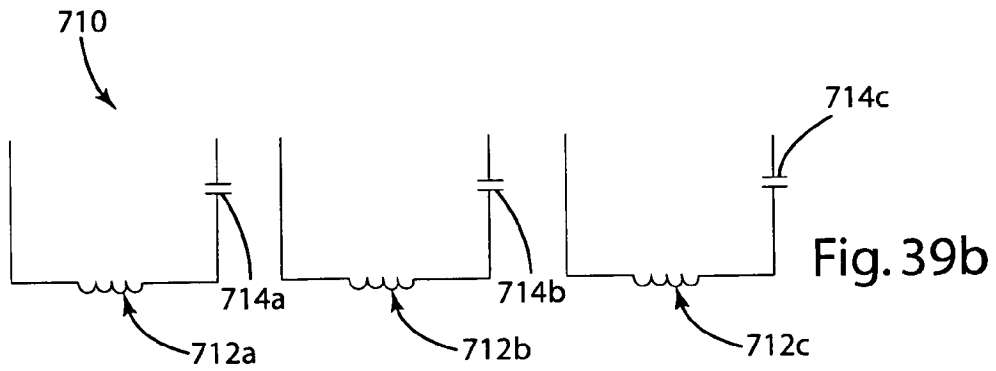
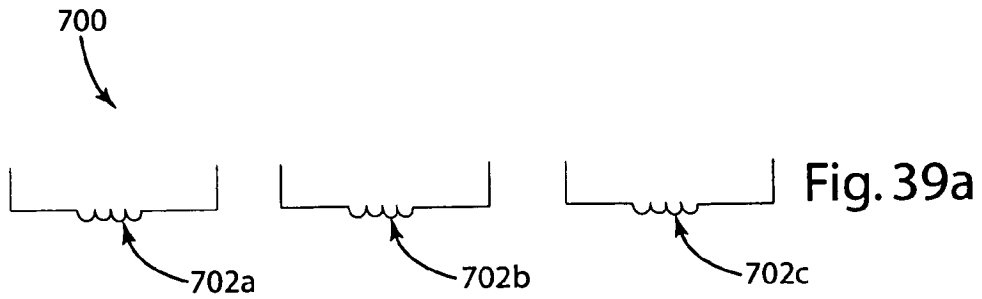

Fig. 38c



**INDUCTIVELY POWERED APPARATUS**

The present invention is a continuation-in-part of U.S. application Ser. No. 10/133,860 entitled "Inductively Powered Lamp Assembly," which was filed on Apr. 26, 2002 (now U.S. Pat. No. 6,731,071) and is a continuation-in-part of U.S. application Ser. No. 09/592,194 entitled "Fluid Treatment System," which was filed on Jun. 12, 2000 (now U.S. Pat. No. 6,436,299).

The present application is also a continuation-in-part of U.S. application Ser. No. 10/246,155 entitled "Inductively Coupled Ballast Circuit," which was filed on Sep. 18, 2002 (now U.S. Pat. No. 6,825,620) and is a continuation-in-part of U.S. patent application Ser. No. 10/175,095 entitled "Fluid Treatment System," which was filed on Jun. 18, 2002 (now U.S. Pat. No. 6,673,250), which is a continuation-in-part of U.S. patent application Ser. No. 09/592,194 entitled "Fluid Treatment System," which was filed on Jun. 12, 2000 (now U.S. Pat. No. 6,436,299). U.S. patent application Ser. No. 09/592,194 (now U.S. Pat. No. 6,436,299) claims the benefit under 35 U.S.C. §119(e) of U.S. provisional patent application Ser. No. 60/140,159 entitled "Water Treatment System with an Inductively Coupled Ballast," which was filed on Jun. 21, 1999, and U.S. provisional patent application Ser. No. 60/140,090 entitled "Point-of-Use Water Treatment System," which was filed on Jun. 21, 1999.

The present application is a continuation-in-part of U.S. application Ser. No. 29/165,043 entitled "Bulb," which was filed on Aug. 2, 2002 (now U.S. Pat. No. D476,095); U.S. application Ser. No. 29/165,008 entitled "Bowl Lamp," which was filed on Aug. 2, 2002 (now U.S. Pat. No. D479,356); U.S. application Ser. No. 29/165,012 entitled "Bulb," which was filed on Aug. 2, 2002 (now U.S. Pat. No. D476,094); U.S. application Ser. No. 29/165,005 entitled "Lamp," which was filed on Aug. 2, 2002 (now U.S. Pat. No. D479,892); U.S. application Ser. No. 29/165,009 entitled "Bulb," which was filed on Aug. 2, 2002 (now U.S. Pat. No. D475,471); and U.S. application Ser. No. 29/165,011 entitled "Chime," which was filed on Aug. 2, 2002 (now U.S. Pat. No. D478,834).

**BACKGROUND OF THE INVENTION**

The present invention relates to wireless power supplies, and more particularly to inductively powered devices.

The principles of inductive power transfer have been known for many years. As a result of mutual inductance, power is wirelessly transferred from a primary coil (or simply "primary") in a power supply circuit to a secondary coil (or simply "secondary") in a secondary circuit. The secondary circuit is electrically coupled with a device, such as a lamp, a motor, a battery charger or any other device powered by electricity. The wireless connection provides a number of advantages over conventional hardwired connections. A wireless connection can reduce the chance of shock and can provide a relatively high level of electrical isolation between the power supply circuit and the secondary circuit. Inductive couplings can also make it easier for a consumer to replace limited-life components. For example, in the context of lighting devices, an inductively powered lamp assembly can be easily replaced without the need to make direct electrical connections. This not only makes the process easier to perform, but also limits the risk of exposure to electric shock.

The use of inductive power transfer has, however, for the most part been limited to niche applications, such as for connections in wet environments. The limited use of induc-

tive power transfer has been largely the result of power transfer efficiency concerns. To improve the efficiency of the inductive coupling, it is conventional to carefully design the configuration and layout of the primary and secondary coils. The primary and the secondary are conventionally disposed within closely mating components with minimal gap between the primary and the secondary. For example, the primary is often disposed within a base defining a central opening and the secondary is often disposed within a cylindrical component that fits closely within the central opening of the base. This and other conventional constructions are design to provide close coaxial and radial alignment between the primary coil and the secondary coil. Several specific examples of patents that reflect the conventional approach of providing a fixed, predetermined physical relationship between the primary and secondary coils include: U.S. Pat. No. 5,264,997 to Hutchisson et al, which discloses an inductive lamp with coaxial and closely interfitting primary and secondary coils; U.S. Pat. No. 5,536,979 to McEachern et al, which discloses an inductive charging device in which the device to be charged is fitted closely within a cradle to position the coils in a fixed, predetermined relationship; U.S. Pat. No. 5,949,155 to Tamura et al, which discloses a shaver with adjacent inductive coils set in a fixed relationship; U.S. Pat. No. 5,952,814 to Van Lerberghe, which discloses an inductive charger for a telephone wherein the physical relationship between the primary and secondary coils is fixed; and U.S. Pat. No. 6,028,413 to Brockman, which discloses a charging device having a mechanical guide for ensuring precise, predetermined alignment between the inductive coils. The conventional practice of providing precise alignment between the primary and secondary coil has placed significant limitation on the overall design and adaptability of inductively powered devices. Further, in conventional inductive systems, the power supply circuit, which drives the primary coil, and the secondary circuit, which inductively receives power from the primary, are designed and carefully tuned to match with one another to maximize the efficiency of the inductive coupling. This too has placed significant limitations on the overall design and adaptability of inductively powered devices.

**SUMMARY OF THE INVENTION**

The aforementioned problems are overcome by the present invention wherein an inductively powered device is provided with a mechanism for varying the relative position between the primary and the secondary to control the amount of power supplied to the load. In one embodiment, the present invention is incorporated into a dimmable lamp assembly in which a primary is mounted to the lamp base and the secondary is mounted to the lamp assembly. The brightness of the lamp is controlled by adjusting the distance between the lamp assembly and the lamp base.

In a second embodiment, the present invention is incorporated into a dimmable lamp assembly in which the lamp brightness is controlled by varying the relative angular orientation of the primary and the secondary. In this embodiment, the primary is generally ring-shaped and the secondary is pivotally mounted within the ring. The lamp assembly includes a mechanical dimmer that rotates either the primary or the secondary so that their relative angular orientation varies. The variation in relative orientation varies the amount of power transferred to the secondary, thereby varying the brightness of the lamp.

In another embodiment, the present invention is incorporated into a wind chime having one or more lamps that vary

3

in brightness based on the movement of the chimes. In this embodiment, a plurality of chime assemblies is suspended within a primary coil, with each chime assembly being individually movable. Each chime assembly includes a secondary disposed at its upper end within the magnetic field of the primary. As the wind blows, the chime assemblies swing with respect to the primary, thereby varying the locations and orientation of the secondary coils within the magnetic field of the primary. This causes the brightness of the wind chimes to vary in respond to the wind.

In yet another embodiment, the present invention provides an infinitely adjustable power supply for use with electrically powered devices where it is desirable to adjust the magnitude of power supplied to the device. The power supply includes an inductive coupling disposed between the power supply and the load. The inductive coupling includes a primary and a secondary. The infinitely adjustable power supply also includes an adjustment mechanism for selectively varying the relative position between the primary and the secondary, such as distance or angular orientation. The adjustment mechanism permits adjustment of the coupling coefficient and consequently the magnitude of power induced in the secondary and supplied to the load.

In a second aspect, the present invention is directed to an inductive power supply station that is capable of providing power to a plurality of inductive powered devices placed at random location and at random orientations with respect to the primary. The inductive power supply station generally includes a single primary arranged about a receptacle that is capable of receiving randomly placed inductively powered devices. The power supply circuit includes circuitry for adjusting the power supplied to the primary as a function of the inductively powered devices present in the receptacle. In one embodiment, the receptacle is a dish, bowl or similar structure in which one or more lamp assemblies can be placed to provide light. Each lamp assembly includes a secondary that inductively receives power from the primary. The brightness of the light can be controlled by varying the number of lamp assemblies placed in the receptacle and by moving the lamp assemblies within the receptacle.

In a third aspect, the present invention provides a secondary with a plurality of coils that are arranged at different orientations. The multiple coils permit the secondary to efficiently receive power when disposed at different orientations with respect to the primary. In one embodiment, a secondary with multiple coils is incorporated into an inductively powered lamp. The lamp assembly can receive maximum induced power when placed at different orientations within the magnetic field of the primary. In another embodiment, the lamp assembly includes a plurality of coils, each being electrically connected to a different light sources, for example, light sources of different colors. By adjusting the orientation of the lamp assembly, the color of emitted light can be varied by altering the respective brightness of the separate light sources.

These and other objects, advantages, and features of the invention will be readily understood and appreciated by reference to the detailed description of the preferred embodiment and the drawings.

#### BRIEF DESCRIPTION OF THE DRAWINGS

FIG. 1 is a perspective view of a desk lamp in accordance with an embodiment of the present invention.

FIG. 2 is a side elevational of the desk lamp of FIG. 1.

FIG. 3 is a partially sectional side elevational view of a portion of the desk lamp of FIG. 1.

4

FIG. 4 is an exploded view of a lamp assembly in accordance with one embodiment of the present invention.

FIG. 5 is a schematic of a secondary circuit.

FIG. 6 is a perspective view of a rack-and-worm mechanical dimmer.

FIG. 7 is a perspective view of the base of a desk lamp showing a dial.

FIG. 8 is a perspective view of the base of a desk lamp showing a slider.

FIG. 9 is a perspective view of the base of a desk lamp showing a rotating top.

FIG. 10 is a perspective view of an alternative mechanical dimmer.

FIG. 11a is a side elevational view of an alternative desk lamp.

FIG. 11b is an enlarged side elevational view of a portion of the alternative desk lamp of FIG. 11a.

FIG. 12 is an enlarged perspective view of a portion of the alternative desk lamp of FIG. 11a showing the mechanical dimmer.

FIG. 13 is a side elevational view of a second alternative desk lamp.

FIG. 14 is an enlarged side elevational view of a portion of the second alternative desk lamp of FIG. 13.

FIG. 15 is a sectional view of a portion of the second alternative desk lamp of FIG. 13 showing the binding tab in the locked position.

FIG. 16 is a sectional view of a portion of the second alternative desk lamp of FIG. 13 showing the binding tab in the open position.

FIG. 17 is a perspective view of a third alternative desk lamp.

FIG. 18 is a perspective view of the mechanical dimmer of the third alternative desk lamp of FIG. 17.

FIG. 19 is a sectional view of a portion of the mechanical dimmer of the third embodiment.

FIG. 20 is a perspective view of a fourth alternative desk lamp.

FIG. 21 is a partially exploded perspective view of the third alternative desk lamp with portions removed to show the arm.

FIG. 22 is a partially exploded perspective view of the third alternative desk lamp with portions removed to show the primary housing.

FIG. 23 is a partially sectional side elevational view of a variable speed fan incorporating an infinitely adjustable power supply in accordance with an embodiment of the present invention.

FIG. 24 is a perspective view of a fifth alternative desk lamp.

FIG. 25 is a partially exploded perspective view of the fifth alternative desk lamp of FIG. 24.

FIG. 26 is a partially exploded side elevational view of replacement lamp base in accordance with an embodiment of the present invention.

FIG. 27 is a partially exploded side elevational view of an alternative replacement lamp base.

FIG. 28 is a perspective view of a portion of the alternative replacement lamp base of FIG. 27.

FIG. 29 is a perspective view of a wind chime in accordance with an embodiment of the present invention.

FIG. 30 is a partially exploded perspective view of a portion of the wind chime.

FIG. 31 is a partially exploded perspective view of a chime assembly.

FIG. 32 is a perspective view of a power supply station in accordance with an embodiment of the present invention.

5

FIG. 33 is a partially exploded perspective view of the primary assembly of the power supply station.

FIG. 34 is a partially exploded perspective view of the base of the power supply station.

FIG. 35 is a partially exploded perspective view of a lamp assembly in accordance with an embodiment of the present invention.

FIG. 36 is a perspective view of a secondary having multiple coils in accordance with an embodiment of the present invention.

FIG. 37 is a perspective view of an assembly having multiple secondaries in accordance with an embodiment of the present invention.

FIG. 38a is a schematic diagram of a secondary circuit for use with a secondary having multiple coils.

FIG. 38b is a schematic diagram of an alternative secondary circuit for use with a secondary having multiple coils.

FIG. 38c is a schematic diagram of a second alternative secondary circuit for use with a secondary having multiple coils.

FIG. 39a is a schematic diagram of a circuit for use with an assembly having multiple secondaries.

FIG. 39b is a schematic diagram of an alternative circuit for use with an assembly having multiple secondaries.

FIG. 39c is a schematic diagram of a second alternative circuit for use with an assembly having multiple secondaries.

FIG. 39d is a schematic diagram of a third alternative circuit for use with an assembly having multiple secondaries.

#### DETAILED DESCRIPTION OF THE PREFERRED EMBODIMENT

The present invention is directed to improvements in inductively powered devices. In a first aspect, the present invention provides an inductive coupling in which the relative position between the primary coil ("primary") and the secondary coil ("secondary") is selectively varied to permit control over the amount of power transferred to the secondary and consequently to the inductively powered device. This aspect of the invention is described in connection with various lamp configurations, for example, to permit control over the brightness of the light source. This aspect of the invention is also described in connection with other electrically powered devices where control over the amount of power supplied to the inductively powered device is desired. In a second aspect, the present invention is directed to an inductive power supply station. In this aspect, the present invention provides a receptacle for receiving one or more inductively powered devices at random locations and at random orientations. In one embodiment of this aspect, the secondary includes multiple coils arranged at different orientations so that power can be more efficiently induced in the secondary without precise alignment between the primary and secondary. In one embodiment, the secondary includes three coils oriented along the x, y and z axis of a Cartesian coordinate system so that power can be induced in the secondary regardless of the angular orientation of the secondary with respect to the primary.

An inductively powered desk lamp 10 in accordance with an embodiment of the present invention is shown in FIG. 1. The lamp 10 generally includes a base 12, a lamp assembly 14 and a mechanical dimmer 16 (See FIG. 3). The base 12 includes a ballast and power supply circuit 18 that drives a primary 20. The lamp assembly 14 includes a secondary

6

circuit 22 having a secondary 24 that is inductively powered by the primary 20 and that applies power to the light source 26. The mechanical dimmer 16 includes a movable arm 28 that is movably attached to the lamp base 12. The primary 20 is mounted to the arm 28 so that movement of the arm 28 results in movement of the primary 20. The lamp assembly 14 is suspended from the lamp base 12 with the secondary 24 positioned within the electromagnetic field created by the primary 20. The arm 28 is mechanically movable to vary the position of the primary 20 with respect to the lamp assembly 14 (and consequently the secondary 24), thereby varying the coupling coefficient between the primary 20 and secondary 24. Changes in the coupling coefficient result in variation in the power transferred to the lamp assembly 14 and ultimately in the brightness of the light source 26. This aspect of the present invention is described in connection with a dimmable lamp 10. The present invention is, however, well-suited for use in virtually any application where variation in the amount of power transferred to the secondary circuit 20 is desired. For example, as described in more detail below, the present invention may be used to provide infinitely adjustable control over the amount of power supplied to a device up to the capacity of the power supply circuit.

As noted above, the desk lamp 10 of the illustrated embodiment generally includes a base 12, a lamp assembly 14 and a mechanical dimmer 16. The lamp base 12 generally includes a pedestal 30, a shaft 32 and a primary housing 34. The pedestal 30 of the illustrated embodiment is generally disc-shaped having a diameter of sufficient size to provide a stable support for the shaft 32 and lamp assembly 14, an internal void 31 adapted to house the power supply circuit 18 and portions of the mechanical dimmer 16. The shaft 32 extends upwardly from the pedestal to receive the lamp assembly 14. In the illustrated embodiment, the shaft 32 is somewhat "?"-shaped, providing an aesthetically pleasing visual appearance. The shaft 32 terminates at its upper end in a hook 36 or other connection element configured to receive the ring 38 of the lamp assembly 14. The primary housing 34 is generally ring-shaped and is hollow to provide a shell or housing for the primary 20. The primary housing 34 is mounted to the arm 28 to support the primary 20 in a position generally encircling the secondary housing 25 of the lamp assembly 14. The illustrated pedestal 30 and shaft 32 are provided with a desired aesthetic appearance. The present invention is easily adapted for use with lamps of a wide variety of designs. Accordingly, the design and configuration of the illustrated base 12 should not be interpreted as a limitation on the present invention. The power supply circuit 18 may be a conventional inductive power supply circuit, however, in one embodiment, the power supply circuit 18 includes a resonance seeking ballast, such as the ballast disclosed in U.S. application Ser. No. 10/246,155 entitled "Inductively Coupled Ballast Circuit," which was filed on Sep. 18, 2002, and is incorporated herein by reference. In the illustrated embodiment, the principle components of the power supply circuit 18 are housed within the void 31 in pedestal 30, for example, as shown in FIG. 3. The location of the components of the power supply circuit 18 may, however, vary from application to application depending primarily on the lamp design and desired aesthetics. For example, the principle components of the power supply circuit 18 can alternatively be disposed at other locations in or on the pedestal 30 or may be disposed in or on the shaft 32. As a further alternative, some or all of the components of the power supply circuit 18 can be integrated into a wall plug (not shown) for the lamp 10. In the illustrated embodi-

ment, the primary 20 is generally ring-shaped and is mounted within a generally ring-shaped primary housing 34. The primary housing 34 defines a central opening 35 that is of sufficient dimension to receive at least a portion of the lamp assembly 14. The size, shape and orientation of the primary 20 (and primary housing 34) can vary from application to application depending in part on the specific design characteristics of the lamp or other inductive device. In the described embodiment, the primary 20 has an inner diameter of 1.25 inches and includes 50 turns of wire 63 wrapped circumferentially around a generally conventional plastic bobbin 33. The wire 63 may be straight 26-gauge wire. Additionally, in this particular embodiment, the values of capacitors 271 and 272 in the above-referenced patent application are 66 nF.

The lamp assembly 14 generally includes a light source 26, such as an incandescent bulb, that is powered by a secondary circuit 22 (See FIGS. 4 and 5). In this embodiment, the light source 26 is custom formed to provide the desired aesthetic appearance. The upper end of the light source 26 is shaped to define a small ring 28 that permits the light source 26 to be hung from a hook 36 defined at the end of shaft 32. The custom-formed lamp of the illustrated embodiment is merely exemplary, and the light source 26 may vary from application to application as desired. As an alternative to the custom-formed lamp 26, the lamp assembly 14 may include a conventional lamp (not shown) that is contained within a housing (not shown) designed to provide the desired aesthetic appearance. For example, the custom-shaped light source 26 can be replaced by a standard incandescent light source that is installed within an ornate and aesthetically pleasing housing. In this alternative embodiment, the secondary circuit 22 may also be enclosed within the housing.

As noted above, the lamp assembly 14 includes a secondary circuit 22 that provides power to the lamp 26. The secondary circuit 22 includes a secondary 24 that is inductively driven by the primary 20. A schematic diagram of the secondary circuit is shown in FIG. 5. In this embodiment, the light source 26 is a custom-formed incandescent 30-watt bulb. The light source 26 is electrically connected in series with the secondary 24 and, if desired, a capacitor 60. In this embodiment, the secondary 24 has a diameter of 0.25 inches and includes 24 turns of wire 64 wrapped circumferentially around a generally conventional plastic bobbin 62. The wire 64 may be straight 26-gauge wire. The optional capacitor 60 is intended to improve the power factor of the secondary circuit 22 by offsetting the inductance of the secondary 24, as described in more detail in U.S. application Ser. No. 10/133,860 entitled "Inductively Powered Lamp Assembly," which was filed on Apr. 26, 2002 and is incorporated herein by reference. In this embodiment, the capacitor 60 includes a capacitance of 33 nF. The characteristics of the secondary circuit 22, including the secondary 24 and the capacitor 60, may vary from application to application depending primarily on the characteristics of the light source and the power supply. In fact, as noted above, the capacitor 60 is optional and may be eliminated altogether in some applications. Although this embodiment includes an incandescent light source 26, the present invention can alternatively include essentially any other electromagnetic radiation emitting device, such as a gas discharge bulb or a light emitting diode.

As described above, the desk lamp 10 is provided with a mechanical dimmer 16 for controlling the brightness of the light source 26. In the illustrated embodiment, the mechanical dimmer 16 is incorporated into the base 12 and shaft 32

to provide vertical movement of the primary housing 34 (and consequently the primary 20) and vary the physical distance between the primary 20 and the secondary 24. As shown, the primary housing 34 is mounted on movable arm 28. In this embodiment, the arm 28 extends through a vertical slot 50 in the shaft 32 and is connected to the rack 72 of a rack-and-worm assembly 70. In this embodiment, the lamp base 12 may include a dial 66a (See FIG. 7), a slider 66b (See FIG. 8) or a rotating top 66c (See FIG. 9) for controlling movement of the mechanical dimmer 16. The rack-and-worm assembly 70 translates rotational movement of the dial 66a, slider 66b or rotating top 66c into vertical movement of the primary 20 in accordance with conventional mechanical principles. More specifically, movement of dial 66a, slider 66b or rotating top 66c causes rotation of worm gear 74, which is rotatably fixed within the lamp base 12 or shaft 32. In the illustrated embodiment, dial 66a is connected to worm gear 74 by spur gear 68. As a result, rotational movement of dial 66a causes rotational movement of spur gear 68 and ultimately worm gear 74. Movement of worm gear 74 in turn causes vertical linear movement of the rack 72 and consequently the primary 20. As perhaps best shown in FIG. 6, the rack 72 includes longitudinal slots 73 that are interfitted with corresponding ribs (not shown) on the interior of the shaft 32. This interface permits vertical movement of the rack 72 within the shaft 32. Because of the non-reversible nature of a worm gear assembly (i.e. the worm 74 can move the rack 72, but the rack 72 cannot rotate the worm gear 74), it provides a "self-locking" mechanical dimmer 16. The electrical leads (not shown) running from the power supply circuit 18 to the primary housing 34 are provided with sufficient slack to permit the desired range of motion. Alternatively, sliding contacts (not shown) can be provided to maintain an electrical connection between the power supply circuit 18 and the primary 20 throughout the entire range of motion of the mechanical dimmer 16.

An alternative mechanical dimmer 80 is shown in FIG. 10. In this alternative embodiment, the inner end of the arm 82 includes a nut 84 that is movable mounted over a threaded rod 86. The height of the arm 82 is adjusted by rotating the threaded rod 86, which causes the nut 84 to move up and down the shaft of the rod 86. The rod 86 may be rotated using essentially any type of control, such as dial 66a, slider 66b or rotating top 66c. As with the rack-and-worm embodiment described above, slack electrical leads, sliding contacts or other similar mechanisms can be provided to maintain electrical connection throughout the desired range of motion of the arm 82.

The mechanical dimmer may alternatively be configured to provide movement of the lamp assembly 14 with respect to the primary 20. This alternative may be preferable in some applications because it may simplify the electrical configuration of the system. More specifically, because there is no relative movement between the power supply circuit 18 and the primary 20, wires or other electrical connections can be run directly from the power supply circuit 18 to the primary 20 without any accommodation for relative movement (e.g. slack electrical leads or sliding contacts). Further, because the lamp assembly 14 is self contained, there is no need to run electrical connections to the lamp assembly 14. In one embodiment of the desk lamp 10' manufactured in accordance with this alternative, the shaft 32' includes a plurality of notches 40a-c' capable of receiving the lamp assembly 14' (See FIGS. 11a-b and 12). In this embodiment, the upper end of the lamp assembly 14' is provided with an enlarged ring 38' capable of being fitted into the notches 40a-c'. As illustrated, the lamp assembly 14' can be suspended from

different notches **40a-c'** to vary the position of the secondary housing **25'** with respect to the primary housing **34'**. This in turn varies the brightness of the lamp assembly **14'**. In a second embodiment of an alternative desk lamp **10''**, the shaft **32''** is manufactured from a flexible material that is capable of bending to vary the position of the lamp assembly **14''** with respect to the primary housing **34''**, and consequently the position of the secondary with respect to the primary. In some applications, the flexible shaft **32''** may have little or no resiliency so that it remains in whatever position it is bent into under acted on. In other applications, the flexible shaft **32''** may be resilient so that a mechanism is required to hold the shaft **32''** in the desired position. In one embodiment of this type of application shown in FIGS. **13-16**, a weight **42''** is fitted over and movable along the shaft **32''** to set and maintain the shaft **32''** at the desired bend (See FIGS. **13** and **16**). In one embodiment, the weight **42''** is fitted over the shaft **32''** and includes a generally conventional, spring-loaded binding clip **50''** that selectively locks the weight in place on the shaft **32''**. In operation, spring **52''** biases the binding clip **50''** into a binding position on the shaft **32''**. To move the weight, the binding clip **50''** is pushed against the bias of spring **52''** into a released position in which the binding clip **50''** is free to slide along the shaft **32''**. In a third embodiment of the desk lamp **10'''**, a counterbalance assembly **44'''** is used to set the position of the lamp assembly **14'''**. In this embodiment, the shaft **32'''** is preferably hollow, defining an internal space (not shown) to contain the counterbalance assembly **44'''**. The lamp assembly **14'''** is suspended from the shaft **32'''** by a cable **48'''**. The cable **48'''** extends through the internal space in the shaft **32'''** and is fixed to the counterbalance assembly **44'''**. A ring **40'''** is mounted to the free end of the cable **48'''** to interconnect with the lamp assembly ring **38'''**. As best shown in FIG. **18**, the counterbalance assembly **44** generally includes a spring **50'''** (or other biasing mechanism) with a tension that offsets the weight of the lamp assembly **14'''**. The counterbalance assembly **44** also includes a pair of rollers **52a-b'''** that firmly entrap the cable **48'''**. The rollers **52a-b'''** are fitted with Bellville washers **54a-b'''** to provide a limiting brake that retains the cable **48'''** in a given position (See FIG. **19**). By offsetting the weight of the lamp assembly **14'''**, the counterbalance assembly **44** holds the lamp assembly **14'''** in the position selected by the user. This allows the user to set the brightness of the lamp assembly **14'''** simply by raising or lowering the lamp assembly **14'''**. Alternatively, the spring **50'''** can be replaced by a counterbalance weight (not shown) having approximately the same weight as the lamp assembly **14'''**.

In a further alternative embodiment (not shown), the mechanical dimmer may include a mechanism for moving the secondary within the lamp assembly rather than moving the entire lamp assembly. For example, the lamp assembly may include a secondary that is slidably movably mounted along a fixed shaft so that the user can slide the secondary up or down the shaft to control the brightness of the lamp assembly (not shown). Alternatively, the secondary may be rotatably mounted within the secondary housing to permit changes to the angular orientation of the secondary, for example, by mounting the secondary on a ball joint (not shown). Knobs or handles (not shown) may protrude through slots in the secondary housing to facilitate the linear or angular movement. The mechanical dimmer may alternatively include a similar mechanism (not shown) for moving the primary within the primary housing.

An alternative inductively powered lamp **100** is shown in FIGS. **20-22**. In this embodiment, the amount of power

supplied to the secondary component is controlled by varying the relative angular orientation of the secondary **124** with respect to the primary **120**. The lamp **110** generally includes a pedestal **130**, a shaft **132** mounted to the pedestal **130** and an arm **133** pivotally mounted to the shaft **132**. In one embodiment, light source **126** is located toward one end of arm **133**, and a counterbalance **150** is located toward the opposite end. The power supply circuit is preferably contained primarily in the pedestal **130** and the shaft **132**, and includes a primary **120** that is mounted toward the top of the shaft **132** in a ring-shaped primary housing **134**. The primary housing **134** may be assembled from injection molded halves **134a-b**. A support **140** extends upwardly from the shaft **132** into the central opening defined by the primary housing **134**. The support **140** defines a concave cradle **142** adapted to receive the arm **133**. The arm **133** includes a sphere **146** disposed at the center of gravity of the arm **133**. The sphere **146** may be assembled from injection molded halves **146a** and **146b**, and includes an outer diameter that corresponds with the inner diameter of the cradle **142**. Accordingly, the arm **133** is mounted to the shaft **132** by resting it upon the support **140** with sphere **146** received in cradle **142**. If desired, the stability of the arm **133** may be improved by heavily weighting the sphere **146**. The illustrated connection permits pivotal movement of the arm **133** in essentially all directions. A variety of alternative joints can be used to connect the arm **133** to the shaft **132**. For example, a standard ball and socket or a standard universal joint can replace the illustrated connection. If desired, a connection providing only limited movement of the arm **133**, such as only vertical or only horizontal movement, may be used.

In operation, the arm **133** is pivotally moved with respect to the shaft **132** causing a rolling action of sphere **146** within cradle **142**. As the arm **133** is moved, the secondary **124** pivots within the magnetic field generated by the primary **120**. This varies the coupling coefficient and the brightness of the light source **126**. The secondary **124** and primary **120** can be oriented to provide the brightest light at the desired position of the arm **133**. For example, the light source **126** may be its brightest when the arm **133** is substantially horizontal and increasingly dim as the arm **133** is moved up or down out of the horizontal position. Alternatively, the light source **126** may become brighter as the arm **133** is moved downward below horizontal. Counterbalance **150** is provided to counter the weight of light source **126**, thereby maintaining the relative position of arm **133** unless acted upon.

The previously described embodiments are directed to lighting applications in which the brightness of the light source is controlled by mechanisms that vary the relative position of primary and secondary. The present invention is not, however, limited to lighting application. Rather, the present invention is well suited for use in essentially any application when control over the amount of power supplied to a device is desired. In this aspect, the present invention provides an infinitely adjustable inductive power supply. By providing a mechanism for controlling the position of the secondary with respect to the primary, the amount of power supplied through the inductive coupling can be controlled. More specifically, by adjusting the distance between the primary and the secondary or the angular orientation between the primary and the secondary, the coupling coefficient of the inductive coupling can be infinitely adjusted within the range of the inductive power supply. In this aspect, the present invention not only provides an infinitely adjustable power source, but it also provides isolation

between the power supply and the inductively powered device, thereby providing safety benefits.

An adjustable power supply in accordance with the present invention is described in more detail in connection with the variable speed fan **200** shown in FIG. **23**. In the illustrated embodiment, the fan **200** includes a conventional electric motor **280** that is housed within a generally conventional fan housing **282**. The fan **200** includes a plurality of fan blades **284a-c** that are mounted to the rotor (not shown) of the electric motor **280**. The electric motor **280** receives power from a power supply circuit **218** having a primary **220** and a secondary **224**. The secondary **224** is movably mounted adjacent to the primary **220** so that movement of the secondary **224** can be used to selectively vary the coupling coefficient of the inductive coupling and, in turn, vary the power supplied to the motor **280**. For example, in the illustrated embodiment, the secondary **224** is mounted to adjustment rod **290**. The adjustment rod **290** is movable inwardly and outwardly with respect to the fan housing, as indicated by arrow A, to move the secondary **224** with respect to the primary **220**. As a result, adjustment of the secondary **224** can be used to selectively control the speed of the fan **200**. Although this embodiment includes a mechanism for moving the secondary **224**, the coupling coefficient can alternatively be adjusted by providing a mechanism for moving the primary **220** or for moving both the primary **220** and the secondary **224**. As noted above, adjustment of the coupling coefficient can be achieved by varying the physical distance between the primary and the secondary and/or by varying the relative angular orientation between the primary and the secondary.

Although described in connection with a variable speed fan, the infinitely adjustable power supply of the present invention is well suited for use in other applications where an adjustable power supply is desired. For example, the power supply may be incorporated into a battery charger (not shown), where the magnitude of the charging power is controlled by adjusting the relative position of the primary and the secondary. As a further example, the power supply may be incorporated into an electric drill (not shown) or other electric power tool, where the power supplied to the electric motor is adjusted by selectively varying the relative position between the primary and the secondary.

In another embodiment, a desk lamp **300** is provided with a lamp assembly **314** that can be positioned in different orientations to vary the characteristics of the light output. In the embodiment illustrated in FIGS. **24** and **25**, the desk lamp **300** includes a lamp assembly **314** that can be positioned in either an upright or inverted position with the two positions creating different lighting effects. As shown, the desk lamp **300** includes a base **312** having a pedestal **330**, a shaft **332** and a primary housing **334**. The primary housing **334** encloses the primary **320** and provides an annular structure for supporting the lamp assembly **314**. In the illustrated embodiment, a transparent plate **340** is mounted within the primary housing **334** to receive the lamp assembly **314**. The plate **340** defines a central opening **342** to nest the lamp assembly **314**. In this embodiment, the lamp assembly **314** is generally "egg-shaped" having a pair of light transmissive housing components disposed on opposite sides of a support ring **360**. More specifically, the lamp assembly **314** includes a transparent housing portion **362** and a translucent housing portion **364**. A separate light source, such as incandescent bulbs, may be positioned within each housing portion **362** and **364** or a single light source may be provided to cast light through both housing portions **362** and **364**. The housing portions **362** and **364**

each have an external diameter that is smaller than the internal diameter of the central opening **342** in the plate **340**. The external diameter of the support ring **360** is, however, greater than the internal diameter of the central opening **342**. As a result, the lamp assembly **314** can be suspended within the central opening **342** upon the support ring **360**.

In use, the character of the light emitted by the lamp **300** can be varied by placing the lamp assembly **314** into the central opening **342** in different orientations. In particular, placing the lamp assembly **314** with the transparent housing portion **362** facing downwardly causes the desk lamp **300** to cast bright, clear light onto the surface below, while casting soft, diffuse light upwardly away from the surface. Inverting the lamp assembly **314** and placing it with the translucent housing portion **364** facing downwardly causes the desk lamp **300** to cast soft, diffuse light downwardly onto the surface below, and bright, clear light upwardly away from the surface. Variations in the light cast by the lamp **300** can also be achieved by providing the housing portions **362** and **364** with different physical and optical characteristics. For example, the two housing portions **362** and **364** can be manufactured from different color materials, have different sizes or shapes or be formed with different lens characteristics, such as variations in focus, magnification and diffusion. Alternatively, differences in the light cast by the lamp **300** can be achieved by providing different light sources within housing **362** and **364**. For example, the two light sources may have different wattage or be of different lamp types. In one embodiment, housing **362** is manufactured from clear glass or polymer, and contains a white incandescent bulb, while housing **364** is manufactured from a translucent glass or polymer, and contains a blue LED.

If desired, the physical distance between the primary and secondary can also be varied by placing the lamp assembly **314** into the central opening **342** in different positions. If the secondary **324** is axially aligned with the support ring **360**, then the secondary **324** will be in substantially the same position with respect to the primary **320** regardless of whether the transparent portion **362** or the translucent portion **364** is facing upwardly. On the other hand, if the secondary coil **324** is axially offset from the support ring **360**, the physical distance between the primary **320** and the secondary **324** will vary depending on the orientation of the lamp assembly **314**. The secondary **324** can be offset from the support ring **360** in either direction depending on the position in which more light output is desired.

In yet another aspect, the present invention is incorporated into a replacement lamp base **400** intended to work in existing screw-base lamps. As shown in FIG. **26**, the lamp base **400** includes a housing **402** containing a power supply circuit **418** that drives a primary **420**. In the illustrated embodiment, the housing **402** is manufactured from two injection-molded halves that close about the power supply circuit **418** and the primary **420**. The housing **402** also includes a screw base **404** that is generally identical to the existing screw-base of conventional incandescent lamps. The screw base **404** is fitted over a lower portion of the housing **402** so that it can be easily screwed into a conventional lamp socket (not shown). Electrical leads (not shown) extend from the screw base **404** to the power supply circuit **418** through corresponding openings in the housing **402**. The housing **402** defines a lamp receptacle **408** adapted to receive an inductive lamp assembly **414**. The receptacle **408** may include a mechanical dimmer that permits the user to mechanically vary the respective position between the primary and the secondary (See FIGS. **27** and **28**). A mechanical dimmer is not, however, necessary, and the receptacle

**408** may include a bayonet fitting or other conventional fitting to secure the lamp assembly **414** within the receptacle **408** in a fixed position. In the alternative embodiment shown in FIGS. 27 and 28, the receptacle **408'** includes cams **410a-b'** that permit the position of the lamp assembly **414'** to be mechanically varied. The cams **410a-b'** interact with corresponding cams **412a-b'** on the undersurface of the secondary housing **403'**, as described in more detail below. The cams **410a-b'** and **412a-b'** may be replaced by threads or other similar mechanisms (not shown) for mechanically selectively varying the depth of the lamp assembly **414'** within the receptacle **408'**. To help to retain the lamp assembly **414** in the desired position within the receptacle **408**, the receptacle **408** and the secondary housing **403** are configured to be frictionally interfitted with one another. In this embodiment, a resilient o-ring **440** may be fitted around the secondary housing **403** to provide a firm frictional interface. The o-ring **440** is preferably seating within an annular recess (not shown) to help prevent it from sliding up or down the housing **403**. Alternatively, the o-ring **440** may be fitted within an annular recess (not shown) in the receptacle **408**. As a further alternative, the mechanical dimmer may include a mechanism for moving the primary **420** within the housing **402** or the secondary **424** within the secondary housing **403**. For example, either coil may be slidably movable along its axis within its corresponding housing to vary the distance between the primary and the secondary, or either coil may be pivotally movable within its housing to vary the angular orientation between the primary and the secondary. The power supply circuit **418** may be generally identical to the power supply circuit **18** described above, with component values selected to match the desired light source or range of light sources.

Referring now to FIG. 26, the lamp assembly **414** generally includes a secondary housing **403** that is adapted to be fitted within the lamp receptacle **408**, a secondary circuit (not shown) contained within the secondary housing **425**, and a light source **426** protruding from the secondary housing **425**. The secondary housing **425** generally includes two injection molded halves that are closed around the secondary **424** and the remainder of the secondary circuit (not shown). As noted above, the secondary housing **403'** of the alternative embodiment shown in FIG. 27 includes cams **412a-b'** on its undersurface to interact with the cams **410a-b'** of the receptacle **408**. The cams **412a-b'** may be eliminated or replaced with other mechanical dimming mechanisms. The secondary circuit is preferably generally identical to the secondary circuit **22** described above, with its component values selected to correspond with the desired light source **426**.

In an alternative embodiment, the present invention is incorporated into inductively powered wind chimes **500** that provide both an audible and visual response to the wind (See FIGS. 29-31). In general, the wind chime **500** includes a primary housing **512** that is suspended from a hanging ring **504** and a plurality of chime assemblies **514a-d** that are suspended from the hanging ring **504** within the center of the primary housing **512**. The primary housing **512** is suspended from the hanging ring **504** by wires **502a-d** or other similar components. The hanging ring **504** is configured to permit the wind chimes **500** to be hung in a wide variety of locations. In the illustrated embodiment, the primary housing **512** includes two injection molded halves **512a-b** that house the primary **520** (See FIG. 30). The power supply circuit (not shown) is contained within the wall plug (not shown). The power supply circuit **518** may be generally identical to the power supply circuit **18** described above,

with component values selected to match the desired light source or range of light sources.

Each chime assembly **514a-d** is suspended within the center of the primary housing **512** by a corresponding wire **506a-d**. The separate wires **506a-d** permit each chime assembly **514a-d** to move freely in response to the wind. Each chime assembly **514a-d** generally includes a chime housing **530**, a light source **526**, a secondary circuit **522** and a chime **532**. The chime housing **530** of the illustrated embodiment includes an opaque upper housing portion **530a** that is suspended from the corresponding wire **506a-d** and a transparent lower housing portion **530b** that is mounted to the undersurface of the upper housing portion **530a**. The chime housing **530** defines an internal space for containing the secondary circuit **522**, including the secondary **524**, the light source **526** and any desired capacitor **528**. The secondary circuit **522** is housed within the upper portion **530a** where it is largely hidden from sight. The light source **526** extends from the upper housing portion **530a** down into the lower housing portion **530b**. The chime **532** is a generally conventional chime and is mounted to the lower end of each chime housing **530**. As a result, as the chime assemblies **514a-d** move in the wind, the chimes **532** collide with one another to create sound. At the same time, as each chime assembly **514a-d** moves, its secondary **524** moves toward and away from the primary **520**. The movement of the secondary **524** within the magnetic field generated by the primary **520** varies the amount of power supplied to the light source **526**, and consequently the brightness of the light source **526**. More specifically, as a chime assembly **514a-d** moves closer to the primary **520**, the amount of power transferred by the primary **520** to the secondary **524** increases and the light source **526** becomes brighter. Conversely, as a chime assembly **514a-d** moves away from the primary **520**, the amount of power transferred to the secondary **524** decreases and the light source **526** becomes dimmer. As a result, increased wind causes increased movement of the chime assembly **514a-d** and increased undulations in the brightness of the light sources **526**.

In a further aspect, the present invention relates to an inductive power supply station having a primary that inductively provides power to one or more inductively powered devices, each having its own secondary coil. In the embodiment illustrated in FIGS. 32-35, the inductive power supply station **600** generally includes a power receptacle **602** and a storage receptacle **608** that are supported by a plurality of legs **606a-c**. A primary **620** is disposed around the power receptacle **602** to generate a magnetic field that provides inductive power to any inductive devices **650a-c** placed within the power receptacle **602**. In the described embodiment, the primary **620** has a diameter of 6.5 inches and includes 50 turns of wire **663** wrapped circumferentially around a generally conventional plastic bobbin **633**. The wire **663** may be litz wire consisting of eight strands of 32-gauge insulated wire wrapped 1 turn per inch, which may provide the primary **620** with improved efficiency. The primary **620** is contained within primary housing **634**. Referring now to FIG. 33, the primary housing **634** includes two annular halves **634a** and **634b** that enclose the primary **620**.

The power receptacle **602** is intended to receive a plurality of inductive devices, such as lamp assemblies **614a-b**, at random locations and random orientations. In the illustrated embodiment, the power receptacle **602** is bowl-shaped and is manufactured from a transparent or translucent material, such as glass or plastic. The bowl-shaped power receptacle **602** is fitted within and supported by the primary housing

634. Although the illustrated power receptacle 602 is bowl-shaped, the receptacle may have a variety of alternative constructions. For example, the bowl-shaped receptacle 602 may be replaced by horizontal surface (not shown) upon which inductively powered devices can be placed or it may be replaced by one or more rings from which inductively powered devices can be suspended. As a further example, the receptacle may be a vertical surface adjacent to which various inductive devices can be suspended, such as an inductively powered wall lamp or an inductively powered clock.

As noted above, the illustrated power supply station 600 also includes a storage receptacle 608 mounted to legs 606a-c, for example, by screws or other fasteners. The storage receptacle 608 provides a place for storing lamp assemblies, such as lamp assembly 614c, and other inductively powered devices when they are not in use. In this embodiment, the storage receptacle 608 is bowl-shaped, to complement the shape of the power receptacle 602, and is mounted between the legs 606a-c of the station 600 below the power receptacle 602 and above the base 612. The size, shape, configurations and location of the storage receptacle may vary from application to application as desired. Alternatively, the storage receptacle 608 may be eliminated.

The power supply station 600 also includes a power supply circuit 618 that supplies power to a primary 620. In the illustrated embodiment, the power supply circuit 618 is disposed within lamp base 612. Referring now to FIG. 34, the lamp base 612 generally includes an upper housing 612a and a lower housing 612b that enclose the power supply circuit 618. The power supply circuit 618 includes a power switch 690 that is actuated by button 692. The button 692 extends down through a corresponding aperture 694 in the upper housing 612a to engage the switch 690. The button 692 may be translucent and the power supply circuit 618 may include a pair of power-indicating LEDs 696a-b that illuminate the button 692 when the power is on. In this embodiment, a power supply cord 698 penetrates the lower housing 612b and is electrically connected to power-in socket 699 to provide AC power to the power supply circuit 618. Electrical leads (not shown) extend from the power supply circuit 618 to the primary 620 through a wiring channel (not shown) in one of the legs 606a-c. The power supply circuit 618 is preferably identical to power supply circuit 18 described above. This power supply circuit 618 has the ability to monitor the power supplied to the primary 620 to determine certain characteristics of the cumulative load (e.g. the inductively powered devices placed in the power receptacle 602), and then to adjust the characteristics of the power supplied to the primary 620 as a function of the monitored values. In one embodiment, the power supply circuit 618 monitors the current supplied to the primary 620 and adjusts the frequency of the power supplied to the primary 610 based on the value of the current.

In the illustrated embodiment, the inductively powered devices are a plurality of lamp assemblies 614a-c. As perhaps best shown in FIG. 35, each of the lamp assemblies 614a-c generally includes a lamp housing 604 that encloses a light source 626a-d and a secondary circuit 622. In this embodiment, the lamp housing 604 is assembled from two glass or injection-molded plastic halves 604a-b, at least one of which is manufactured from a transparent or translucent material. The halves 604a-b are interconnected by cover ring 640, for example, by adhesives or threads. A separate o-ring 642a-b may be fitted between the cover ring 640 and each half 604a-b. The secondary circuit 622 is enclosed within the lamp housing 604, and generally includes a

secondary 624 and an optional capacitor 630 that are connected in series with light source 626a-d. In the illustrated embodiment, the light source includes a plurality of LEDs 626a-d. In this embodiment, the secondary 624 has a diameter of 2 inches and includes 27 turns of 26-gauge straight wire 664 wrapped circumferentially around a generally conventional plastic bobbin 662. The characteristics of the secondary 624 (e.g. number of turns, diameter of coil, type of wire) and optional capacitor 630 (e.g. capacitance value) are selected to correspond with the light source 626a-d and the power supplied by the primary 620.

To improve the flexibility of the inductive power supply station, an inductive device may include a secondary having a plurality of coils that are arranged at different orientations. In applications where only a single coil is used, it is possible that a device randomly placed within a power receptacle will be located with the coil oriented substantially parallel to the magnetic field. In such situations, the secondary may not receive sufficient power to power the device from the primary. The use of multiple coils addresses this problem by providing a secondary coil arrangement that significantly increases the likelihood that at least one coil will at least substantially intersect the flux lines of the magnetic field generated by the primary. For example, an inductive device may include a secondary with two coils that are oriented at 90 degrees to one another. With this configuration, at least one of the two coils is likely to extend across the flux lines of the magnetic field and receive power from the primary. The number of separate coils may vary from application to application, for example, the inductive device may include 3, 4, 6 or 8 coils at different orientations to provide improved efficiency in a wide variety of orientations. By providing a sufficient number of coils at different orientations, the inductive device can be configured to receive power from the primary regardless of the orientation of the inductive device.

In one embodiment, the inductively power device includes a secondary 670 having three separate coils 672a-c; one oriented along each of the x, y and z axes of a Cartesian three-dimensional coordinate system. As shown in FIG. 36, an arrangement of three bobbins 660a-c is provided to receive the three coils 672a-c. The diameters of the three bobbins 660a-c vary so that the bobbins 660a-c can be fitted one within the other. Given that the power induced in a secondary is proportional to the diameter of the secondary, the use of differently sized bobbins may result in an imbalance in the power supplied to each secondary. In applications where it is desirable to balance the power induced in the different coils 672a-c, additional turns of wire can be added to the smaller bobbins 660b-c, with the precise number of additional turns added to each smaller bobbin depending primarily on its size. For example, if the outermost secondary 672a includes seven turns, it may be desirable to include eight turns on the middle secondary 672b and nine turns on the innermost secondary 672c. Alternatively, a spherical bobbin (not shown) can be provided, with each coil being wrapped about the spherical bobbin at the desired location and in the desired orientation, for example, about the x, y and z axes. This embodiment reduces the differences in the diameters of the three secondaries, thereby improving the balance of the coils. Although the secondary with multiple coils is described in connection with the inductively powered lamp assembly 614, a secondary with multiple coils can be incorporated into essentially any inductively power device to maximize power transfer in various orientations of the device within the magnetic field. For example, a cell phone (not shown) or personal digital assistant (not shown) can be provided with an inductively powered battery

charger having a secondary with a single coil, such as secondary 622 above, or with multiple coils, such as secondary 670. In this example, a cell phone or personal digital assistant having a secondary with multiple coils can be placed randomly within the power receptacle 602 without concern for its orientation because the secondary 670 will be able to obtain sufficient power to charge the device in any orientation.

FIGS. 38a-c show circuit diagrams for three embodiments of the three-coil secondary 670. FIG. 38a illustrates a circuit 680 that provides DC power from three separate coils 672a-c. As shown, the three coils 672a-c are connected in parallel to the load, a capacitor 674a-c is connected in series between each coil 672a-c and the load. In this embodiment, the value of each capacitor 674a-c and each diode 676a-c is selected to provide a resonant circuit for the load-side of the circuit. This circuit 680 combines the power induced within each of the coils using the capacitors to provide resonance with the load, and diodes 674a-c rectifying the voltage output from circuit 680. Alternatively, diodes 676a-c can be eliminated from the circuit 680 to provide AC power to the load.

FIG. 38b illustrates a half wave rectifier circuit 680' that provides DC power from three separate coils 672a-c'. As shown, the three coils 672a-c' are connected in parallel to the load through an arrangement of diodes 676a-f' is connected in series between each coil 672a-c' and the load. In this embodiment, the value of each diode 676a-f' is determined based primarily on the characteristics of the load. Additionally, a capacitor 674a-c' is connected in series between one side of the coil 672a-c' and the corresponding diodes 676a-f'. The value of each capacitor 674a-c' is also determined based primarily on the characteristics of the load. This circuit 680' combines the power induced within each of the coils using the capacitors to provide resonance with the load, and diodes 676a-c' rectifying the voltage output from the circuit 680'.

FIG. 38c illustrates a full wave rectifier circuit 680'' that provides DC power from three separate coils 672a-c''. As shown, the three coils 672a-c'' are connected in parallel to the load through an arrangement of diodes 676a-l'' is connected in series between each coil 672a-c'' and the load. In this embodiment, the value of each diode 676a-l'' is determined based primarily on the characteristics of the load. Additionally, a capacitor 674a-c'' is connected in series between one side of the coil 672a-c'' and the corresponding diodes 676a-l''. The value of each capacitor 674a-c'' is determined based primarily on the characteristics of the load. All three of these circuit 680, 680' and 680'' perform the function of providing DC power. Circuit 680 is likely the least expensive design, while circuit 680' provides the best control over the DC output, for example, circuit 680'' likely provide less fluctuation in the output compared to the other two embodiments.

In use, the illustrated inductive power supply station 600 and accompanying light assemblies 614a-c provide a distinctive and aesthetically pleasing light source. The amount and character of light cast by the system can be adjusted by varying the number of lamp assemblies 614a-c placed within the receptacle 602, by varying the position of each lamp assembly 614a-c and by varying the orientation of each lamp assembly 614a-c within the receptacle. For example, additional lamp assemblies 614a-c can be added to the receptacle to increase the brightness of light cast by the system. Similarly, the location or orientation of a given lamp assembly 614a-c can be varied to control the light output of that particular lamp assembly 614a-c.

In an alternative embodiment, the lamp assembly 614 includes two light sources 626a-b that are connected to separate secondaries 624a-b (See FIG. 37). In this embodiment, the two light sources 626a-b are preferably light emitting diodes, each generating light of a different color. The secondaries 624a-b are oriented 90 degrees from each other so that the power supplied to one secondary is inversely proportional to the power supplied to the other secondary. For example, by rotating the lamp assembly 614 with the power receptacle 602, one secondary is moved into a position that more directly intersects the magnetic field generated by the primary 620 while the other is moved to a position that less directly intersects the magnetic field. As a result, the lamp assembly 614 can be rotated within the power receptacle 602 to selectively control the color of the lamp assembly 614 by adjusting the amount of power supplied to each light source 626a-b. For example, with red and blue light sources, the lamp assembly 614 can be rotated to cast light ranging from pure red through purple to pure blue. If desired, a device can be provided with 3 separate secondaries, each oriented 90 degrees from one another, such as along each of the x, y and z axes of a Cartesian three-dimensional coordinate system. In accordance with this alternative, each secondary can drive a separate light source or power a separate electrical device. It should also be noted that the 3 axis configuration can be used to calculate the orientation of the device by comparing the voltages from each secondary. In some applications, it may be desired to provide an inductively powered device with two sets of coils, a first to set to provide power to one or more devices and a second to provide position information. FIGS. 39a-d illustrate circuit diagrams for various multiple secondary circuits. FIG. 39a illustrates a simple three secondary circuit 700 in which each coil 702a-c is connected to a separate load, such as a light source, a single channel of a three-channel position calculating circuit or other inductively powered device. FIG. 39b illustrates an alternative circuit 710 in which a capacitor 714a-c is connected in series between each secondary 712a-c and its corresponding load. In this embodiment, the capacitance value of each capacitor 714a-c is selected primarily as a function of the corresponding load and the inductance of the corresponding secondary to tune the power within each secondary circuit. FIG. 39c illustrates an alternative circuit 720 in which a capacitor 724a-c and a diode 726a-c are connected in series between each secondary 722a-c and its corresponding load. This circuit 720 provides limited rectification to provide a separate source of DC power to each load. In this embodiment, the capacitance value of each capacitor 724a-c and diode 726a-c is selected primarily as a function of the corresponding load and the inductance of the corresponding secondary. FIG. 39d illustrates an alternative circuit 730 in which a capacitor 734a-c and a pair of diodes 736a-f are connected in series between each secondary 732a-c and its corresponding load. This circuit 730 provides half wave rectification to provide a separate source of DC power to each load. In this embodiment, the capacitance value of each capacitor 724a-c and diode 726a-c is selected primarily as a function of the corresponding load and the inductance of the corresponding secondary. Although not illustrated, each secondary may alternatively include a full wave rectification circuit to provide a separate source of DC power to each load.

Although the inductive power supply station 600 is illustrated in connection with a unique lamp construction, the inductive devices may include other types of inductively powered devices. For example, a cell phone, personal digital

assistant or other similar device may include an inductively powered battery charger that is configured to receive power from the inductive power supply station. In such applications, the inductively powered devices can be charged simply by placing it within the power receptacle. The inductively powered device may use the power supplied by the secondary to directly power, rather than simple recharge, the device. For example, a miniature radio, MP3 music player or other media player can be provided with inductive secondary circuits, permitting them to be powered by the power supply station.

The above description is that of a preferred embodiment of the invention. Various alterations and changes can be made without departing from the spirit and broader aspects of the invention as defined in the appended claims, which are to be interpreted in accordance with the principles of patent law including the doctrine of equivalents. Any reference to claim elements in the singular, for example, using the articles "a," "an," "the" or "said," is not to be construed as limiting the element to the singular.

The invention claimed is:

1. An inductively powered device comprising:
  - a power supply circuit having a primary, said power supply circuit applying power to said primary to generate a magnetic field;
  - a secondary assembly having a secondary circuit with a secondary and a load, said secondary being disposed within said magnetic field, said secondary physically spaced from the primary by a distance, said magnetic field inducing a current in said secondary to apply power to said load at a magnitude; and
  - a means for varying the distance between said primary and said secondary in order to control said magnitude of said power applied to said load.
2. The inductively powered device of claim 1 wherein said means for varying said distance between said primary and said secondary includes a secondary assembly support having a plurality of mounting locations each being a different distance from said primary, said secondary assembly being selectively mountable at a different one of said mounting locations.
3. The inductively powered device of claim 1 wherein said means for varying said distance between said primary and said secondary includes a flexible support disposed adjacent to said primary, said secondary assembly being mounted to said flexible support, said flexible support being bendable to vary said distance between said primary and said secondary.
4. The inductively powered device of claim 1 wherein said means for varying said distance between said primary and said secondary includes a support disposed adjacent to said primary and a counterbalance, said secondary assembly being mounted to said support, said support being movable to vary said distance between said primary and said secondary, said counterbalance offsetting the weight of said secondary assembly to retain said secondary assembly in a given position.
5. The inductively powered device of claim 1 wherein said primary is contained within a primary housing, said means for varying said distance between said primary and said secondary includes means for moving said primary within said primary housing.

6. The inductively powered device of claim 1 wherein said means for varying said distance between said primary and said secondary includes means for moving said secondary within said secondary assembly.

7. The inductively powered device of claim 1 wherein said inductively powered device includes a shaft supporting said primary, said means for varying said distance between said primary and said secondary includes means for moving said primary with respect to said shaft.

8. The inductively powered device of claim 1 wherein said means for varying said distance between said primary and said secondary includes a rack and a worm gear, said primary mounted to said rack, said worm gear being operable to cause linear movement of said rack.

9. The inductively powered device of claim 1 wherein said means for varying said respective position between said primary and said secondary includes means for varying an angular orientation between said primary and said secondary.

10. The inductively powered device of claim 9 wherein said primary and said secondary are disposed one within the other; and

wherein at least one of said primary and said secondary is pivotally mounted to the device.

11. The inductively powered device of claim 9 further comprising:

- a shaft supporting said primary;
- an arm supporting said secondary, said arm being mounted for pivot movement with respect to said shaft.

12. The inductively powered device of claim 1 wherein said power supply circuit includes a means for monitoring a characteristic of said power indicative of said load and a means for varying a characteristic of said power based on said monitored characteristic, whereby said power supply circuit varies said power to optimize operation as a function of said one or more inductively powered devices.

13. The inductively powered device of claim 12 wherein said load is further defined as a light source.

14. The inductively powered device of claim 13 wherein said secondary circuit further includes a capacitor electrically connected in series between said secondary and said light source.

15. An inductively powered device comprising:
 

- a power supply circuit having a primary generating a magnetic field;
- a secondary, the secondary not physically in contact with the primary, the primary separated from the secondary by a distance, disposed with said magnetic field, whereby power is induced by said magnetic field in said secondary;
- a load electrically connected to said secondary, said load receiving said power from said secondary; and
- means for varying the distance between said primary and said secondary to vary said power applied to said load.

16. The inductively powered device of claim 15 wherein said means for varying said respective position between said primary and said secondary includes means for varying an angular orientation between said primary and said secondary.